

DWG NO. SBI_LHO_PUNE_12TH_FL_FUR_LAYOUT_01

NOTES:
 THIS DRAWING IS THE SOLE PROPERTY OF 'METAPHORS'.
 IT MUST NOT BE COPIED OR REPRODUCED IN ANYWAY OR
 MADE ACCESSIBLE TO THIRD PARTY WITHOUT THE
 WRITTEN APPROVAL OF THE OWNER.

LEGEND

NOTE:
 ALL DIMENSIONS ARE IN MM.
 DO NOT SCALE THE DRAWING. ONLY WRITTEN DIMENSIONS TO BE
 CONSIDERED.
 ANY DISCREPANCY IN THE DRAWING SHALL BE BROUGHT TO NOTICE TO
 ARCHITECT PRIOR TO EXECUTION.
 THIS DRAWING IS PROPERTY OF ARCHITECT AND SHALL NOT BE
 REPRODUCED OR USED WITHOUT PRIOR PERMISSION OF ARCHITECT
 FOR STRUCTURAL DETAIL. REFER R.C.C. CONSULTANT'S DRAWING.

PROJECT NAME:

SBI-LHO, PUNE

DRAWING TITLE:

SBI_LHO_PUNE_12TH.FLOOR_FURNITURE
 LAYOUT

DATE: 22.10.2024

REV	DATE	DESCRIPTION
1	27-12-2024	AS PER SITE MEASUREMENTS

CONSULTANTS	M.E.P. -
	Landscape -
SCALE	R.C.C. -
N.T.S.	

ARCHITECT'S STAMP & SIGNATURE

DRAWN BY:	SHIKHA	CHK BY:	PM
-----------	--------	---------	----

ARCHITECT:

 Architects & Designers



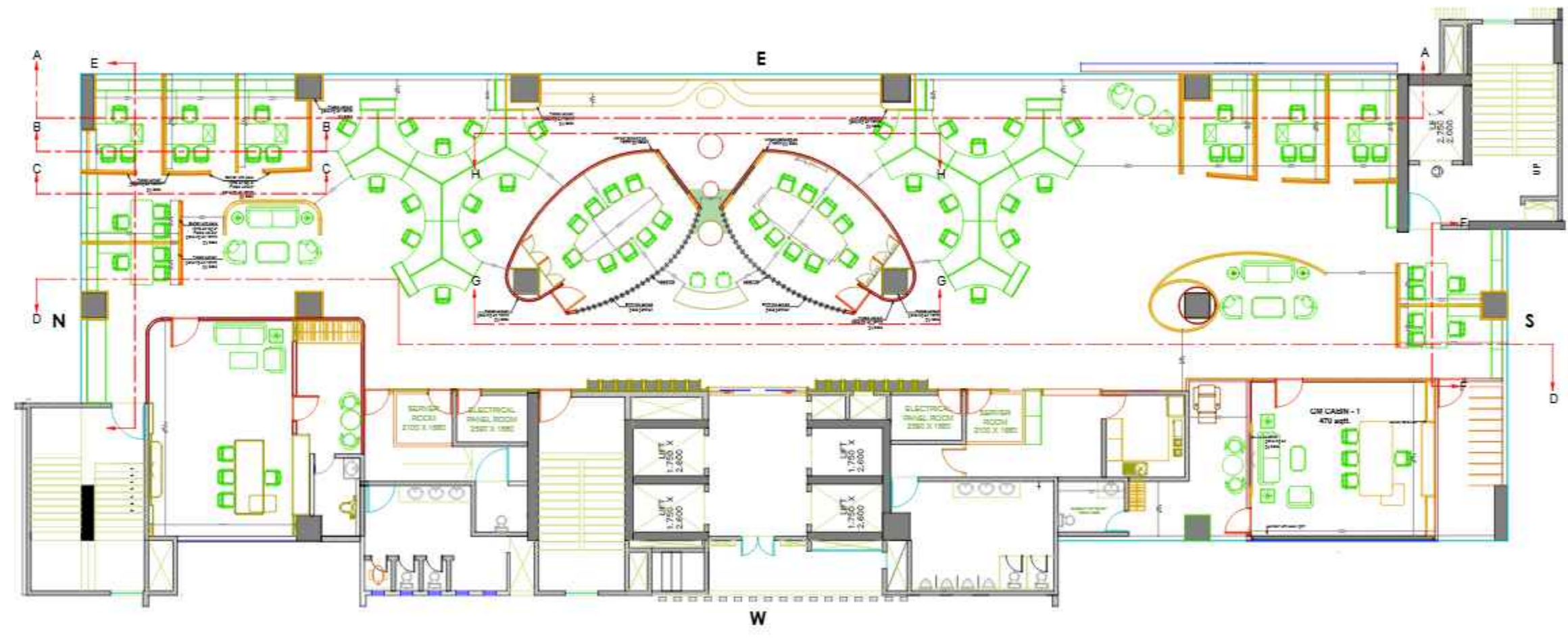





© 2024, Plot: Ganga Bazar, 47 Bangal Road, Colaba (near Pune) 400 005, India
 Phone: +91-22-28875113 Fax: +91-22-28875114 Email: info@metaphorsdesign.com
 Website: www.metaphorsdesign.com

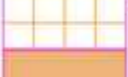

DWG NO. SBI_LHO_PUNE_12TH.FL_CEL_LAYOUT_02

NOTE:
THIS DRAWING IS THE SOLE PROPERTY OF 'METAPHORS'.
IT MUST NOT BE COPIED OR REPRODUCED IN ANYWAY OR
MADE ACCESSIBLE TO THIRD PARTY WITHOUT THE
WRITTEN APPROVAL OF THE OWNER.

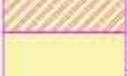
LEGEND

-  gypsum ceiling @2850
-  gypsum ceiling @3000
-  gypsum ceiling @3000
-  modular ceiling @3038
-  leather ceiling @2925
-  wooden band @2900
-  wooden ceiling @2750
-  Alabaster ceiling @3000

NOTE:
ALL DIMENSIONS ARE IN MM.
DO NOT SCALE THE DRAWING. ONLY WRITTEN DIMENSIONS TO BE
CONSIDERED.
ANY DISCREPANCY IN THE DRAWING SHALL BE BROUGHT TO NOTICE TO
ARCHITECT PRIOR TO EXECUTION.
THIS DRAWING IS PROPERTY OF ARCHITECT AND SHALL NOT BE
REPRODUCED OR USED WITHOUT EXPRESS PERMISSION OF ARCHITECT
FOR STRUCTURAL DETAIL. REFER R.C.C. CONSULTANT'S DRAWING.

PROJECT NAME:

SBI-LHO, PUNE

DRAWING TITLE:

SBI_LHO_PUNE_12TH.FLOOR_FALSE
CEILING LAYOUT

DATE: 22.10.2024

REV	DATE	DESCRIPTION
1	27-12-2024	AS PER SITE MEASUREMENTS

CONSULTANTS

M.E.P. -

Landscape -

SCALE
N.T.S.

R.C.C. -

ARCHITECT'S STAMP & SIGNATURE

DRAWN BY: SHIKHA CHK BY: PM

ARCHITECT:

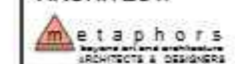





© 2023, PUNE (LHO) BRANCH, 47 BANGALORE ROAD, COLONY (LHO) PUNE 411 016, INDIA
Phone: +91-20-28877511 Fax: +91-20-28877512 Email: info@metaphorsdesign.com
Website: www.metaphorsdesign.com



DWG NO. SBI_LHO_PUNE_12TH.FL.RCP_LAYOUT_04

NOTE:
THIS DRAWING IS THE SOLE PROPERTY OF 'METAPHORS'. IT MUST NOT BE COPIED OR REPRODUCED IN ANYWAY OR MADE ACCESSIBLE TO THIRD PARTY WITHOUT THE WRITTEN APPROVAL OF THE OWNER.

LEGEND

	SPOT LIGHT
	LINEAR LIGHT
	LED LIGHT
	DECORATIVE LIGHT

NOTE:
ALL DIMENSIONS ARE IN MM.
DO NOT SCALE THE DRAWING. ONLY WRITTEN DIMENSIONS TO BE CONSIDERED.
ANY DISCREPANCY IN THE DRAWING SHALL BE BROUGHT TO NOTICE TO ARCHITECT PRIOR TO EXECUTION.
THIS DRAWING IS PROPERTY OF ARCHITECT AND SHALL NOT BE REPRODUCED OR USED WITHOUT EXPLICIT PERMISSION OF ARCHITECT FOR STRUCTURAL DETAIL. REFER R.C.C. CONSULTANT'S DRAWING.

PROJECT NAME:
SBI-LHO, PUNE

DRAWING TITLE:
SBI_LHO_PUNE_12TH.FLOOR_RCP_LAYOUT

DATE: 22.10.2024

REV	DATE	DESCRIPTION
1	26-12-2024	AS PER SITE MEASUREMENTS

	CONSULTANTS
	M.E.P. -
	Landscape -
SCALE N.T.S.	R.C.C. -

ARCHITECT'S STAMP & SIGNATURE

DRAWN BY:	SHIKHA	CHK BY:	PM
-----------	--------	---------	----

ARCHITECT:
 **etaphors**
ARCHITECTS & DESIGNERS

© 2024, PUNE (INDIA) BRANCH, 47/2, BANGALORE ROAD, COLONY (PUNE) 411 004, INDIA
PUNE: +91-20-28875113 | BANGALORE: +91-82-00775113 | EMAIL: info@metaphorsdesign.com
WWW: www.metaphorsdesign.com



DWG NO. SBI_LHO_PUNE_12TH_FL_CON_FUR_LAYOUT_04

NOTES:
 THIS DRAWING IS THE SOLE PROPERTY OF 'METAPHORS'.
 IT MUST NOT BE COPIED OR REPRODUCED IN ANYWAY OR
 MADE ACCESSIBLE TO THIRD PARTY WITHOUT THE
 WRITTEN APPROVAL OF THE OWNER.

LEGEND

NOTE:
 ALL DIMENSIONS ARE IN MM.
 DO NOT SCALE THE DRAWING. ONLY WRITTEN DIMENSIONS TO BE
 CONSIDERED.
 ANY DISCREPANCY IN THE DRAWING SHALL BE BROUGHT TO NOTICE TO
 ARCHITECT PRIOR TO EXECUTION.
 THIS DRAWING IS PROPERTY OF ARCHITECT AND SHALL NOT BE
 REPRODUCED OR USED WITHOUT EXPLICIT PERMISSION OF ARCHITECT
 FOR STRUCTURAL DETAIL, REFER R.C.C. CONSULTANT'S DRAWING.

PROJECT NAME:
 SBI-LHO, PUNE

DRAWING TITLE:
 SBI_LHO_PUNE_12TH.FLOOR_
 CONFERENCE ROOM_LAYOUT

DATE: 22.10.2024

REV	DATE	DESCRIPTION
1	27-12-2024	AS PER SITE MEASUREMENTS

CONSULTANTS

M.E.P. -
 Landscape -
 R.C.C. -

SCALE
 N.T.S.

ARCHITECT'S STAMP & SIGNATURE

DRAWN BY: SHIKHA CHK BY: PM

ARCHITECT:

 Architects & Designers

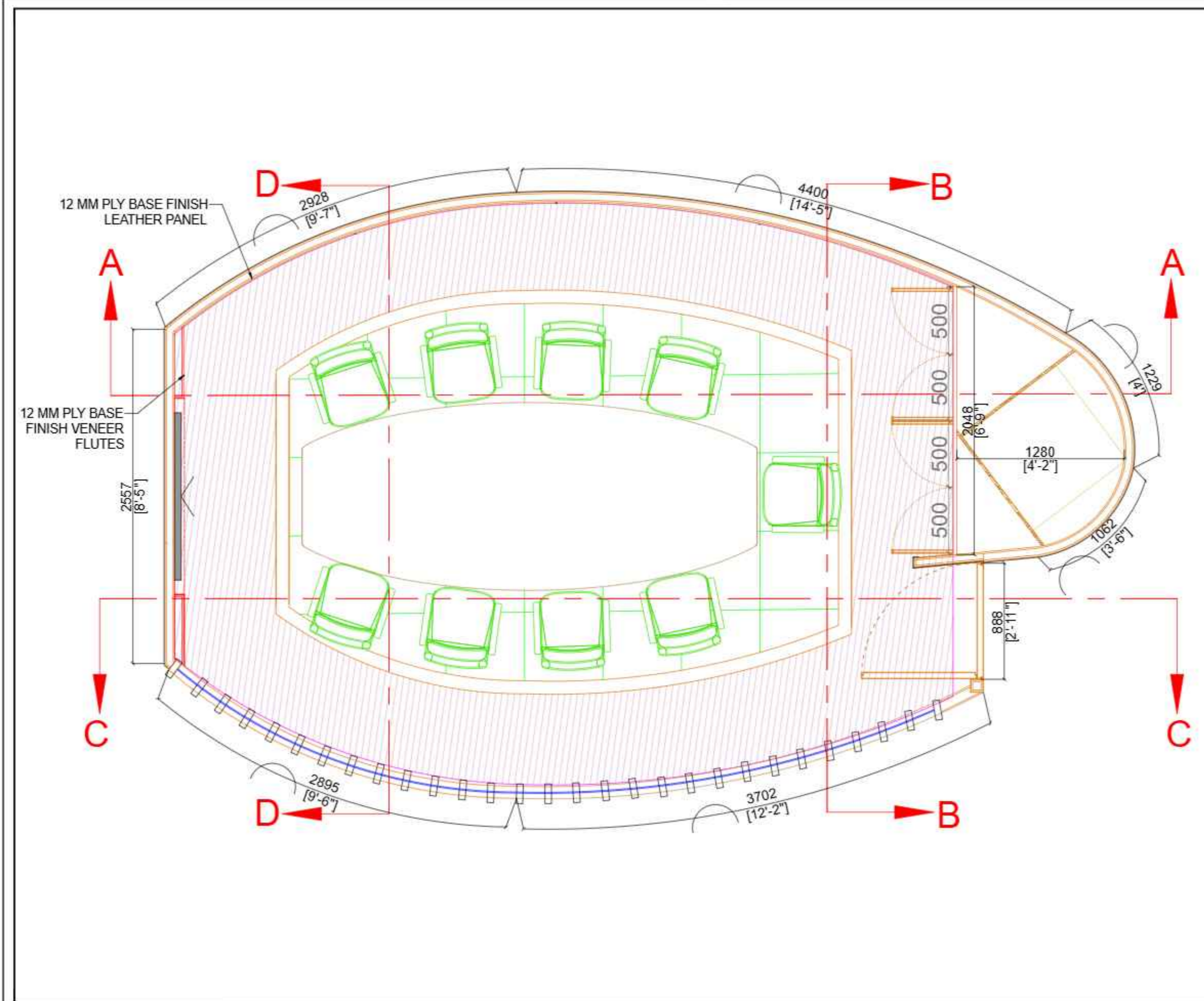
© 2024, Metaphors Architects & Designers, All Rights Reserved. Contact: Metaphors Architects & Designers, Pune. Phone: +91-20-28877513 Fax: +91-20-28877512 Email: info@metaphorsdesign.com Website: www.metaphorsdesign.com



NOTE:
THIS DRAWING IS THE SOLE PROPERTY OF 'METAPHORS'.
IT MUST NOT BE COPIED OR REPRODUCED IN ANYWAY OR
MADE ACCESSIBLE TO THIRD PARTY WITHOUT THE
WRITTEN APPROVAL OF THE OWNER.

LEGEND

NOTE:
ALL DIMENSIONS ARE IN MM.
DO NOT SCALE THE DRAWING. ONLY WRITTEN DIMENSIONS TO BE
CONSIDERED.
ANY DISCREPANCY IN THE DRAWING SHALL BE BROUGHT TO NOTICE TO
ARCHITECT PRIOR TO EXECUTION.
THIS DRAWING IS PROPERTY OF ARCHITECT AND SHALL NOT BE
REPRODUCED OR USED WITHOUT EXPLICIT PERMISSION OF ARCHITECT
FOR STRUCTURAL DETAIL, REFER R.C.C. CONSULTANT'S DRAWING.

PROJECT NAME:

SBI-LHO, PUNE

DRAWING TITLE:

SBI_LHO_PUNE_12TH.FLOOR_CONFERENCE ROOM_SECTIONS

DATE: 22.10.2024

REV	DATE	DESCRIPTION
1	27-12-2024	AS PER SITE MEASUREMENTS

CONSULTANTS	
M.E.P. -	
Landscape -	
SCALE	R.C.C. -
N.T.S.	

ARCHITECT'S STAMP & SIGNATURE:

DRAWN BY: SHIKHA CHK BY: PM

ARCHITECT:
metaphors
ARCHITECTS & DESIGNERS

© 2024, Metaphors Architects, All Rights Reserved. Contact: Metaphors Architects, Pune, India.
Phone: +91-20-28875113 Fax: +91-20-28875114 Email: info@metaphorsdesign.com
Website: www.metaphorsdesign.com

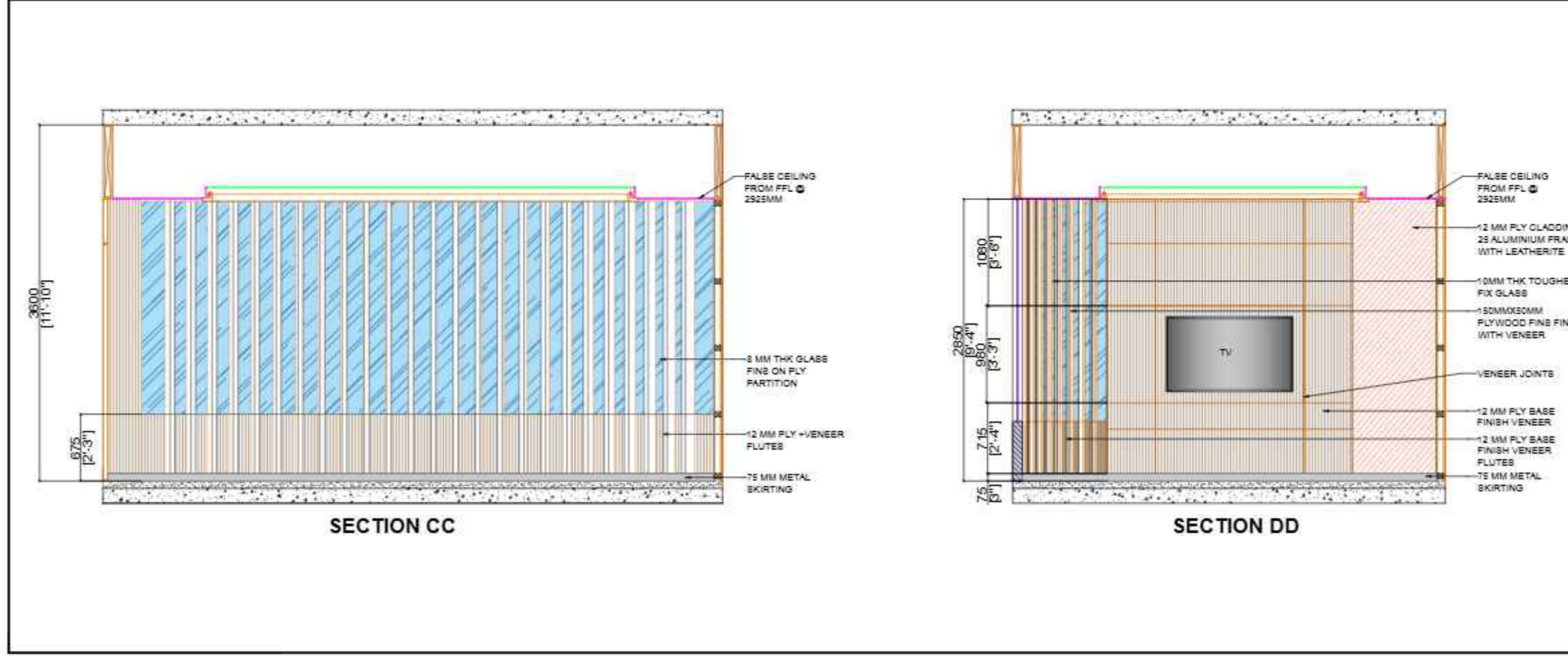
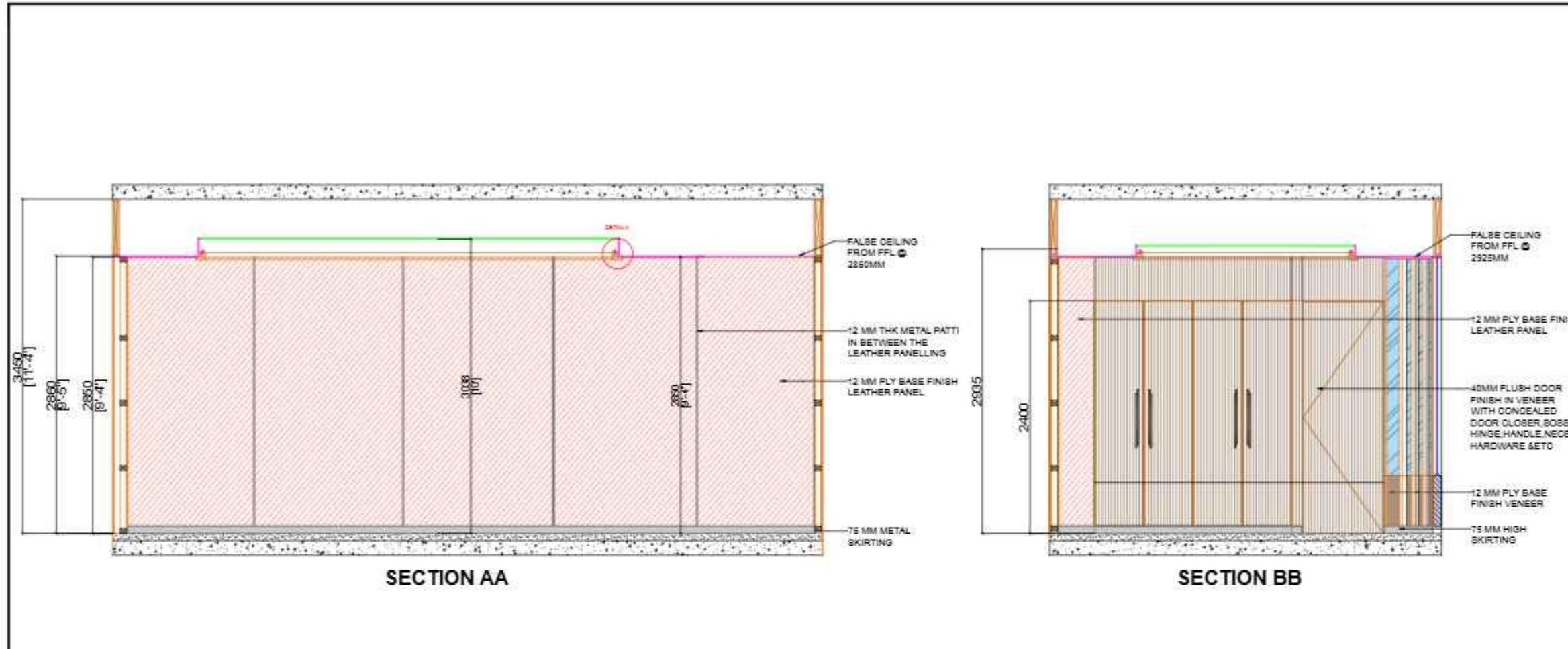

DWG NO: SBI_LHO_PUNE_12TH_FL_CON_FUR_DETAILS_06

NOTES:
 THIS DRAWING IS THE SOLE PROPERTY OF 'METAPHORS'. IT MUST NOT BE COPIED OR REPRODUCED IN ANYWAY OR MADE ACCESSIBLE TO THIRD PARTY WITHOUT THE WRITTEN APPROVAL OF THE OWNER.

LEGEND

NOTE:
 ALL DIMENSIONS ARE IN MM.
 DO NOT SCALE THE DRAWING. ONLY WRITTEN DIMENSIONS TO BE CONSIDERED.
 ANY DISCREPANCY IN THE DRAWING SHALL BE BROUGHT TO NOTICE TO ARCHITECT PRIOR TO EXECUTION.
 THIS DRAWING IS PROPERTY OF ARCHITECT AND SHALL NOT BE REPRODUCED OR USED WITHOUT EXPLICIT PERMISSION OF ARCHITECT FOR STRUCTURAL DETAIL. REFER R.C.C. CONSULTANT'S DRAWING.

PROJECT NAME:
 SBI-LHO, PUNE

DRAWING TITLE:
 SBI_LHO_PUNE_12TH_FLOOR_CONFERENCE_ROOM_FUR_DETAILS

DATE: 22.10.2024

REV	DATE	DESCRIPTION
1	27-12-2024	AS PER SITE MEASUREMENTS

CONSULTANTS
 M.E.P. -
 Landscape -
 R.C.C. -

SCALE
N.T.S.

ARCHITECT'S STAMP & SIGNATURE

DRAWN BY: SHIKHA CHK BY: PM

ARCHITECT:

 metaphors
 architects & designers

© 2024, Plot: LHO, Sector: 12, Pune. All Rights Reserved. Contact: +91 20 28771113. Email: info@metaphorsdesign.com

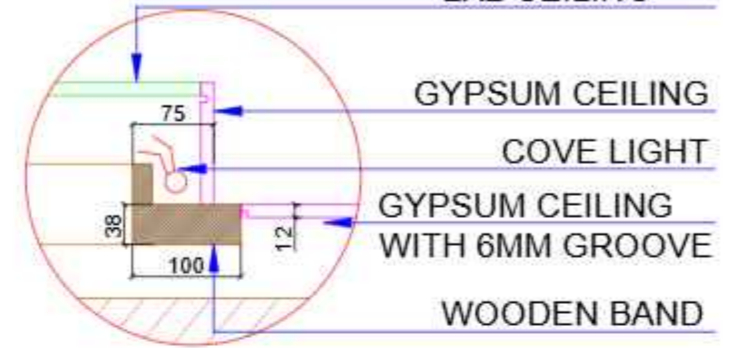
DETAIL A MODULAR GRID 2X2 CEILING



GYPSON CEILING
 COVE LIGHT
 GYPSON CEILING WITH 6MM GROOVE
 WOODEN BAND

6MM FLUTED VENEER ON 12MM PLY BASE
 ALLUMINIUM SECTION FOR SUPPORT
 12 MM PLY
 LEATHER FINISH ON 12 MM PLY BASE
 12MM METAL PATTI
 6MM FLUTED VENEER ON PLY BASE
 12 MM PLY IN ALLUMINIUM SECITONS

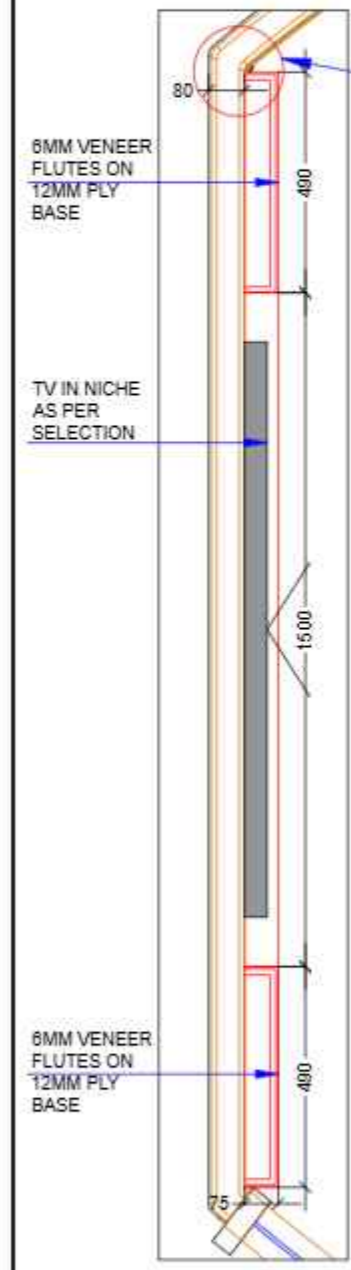
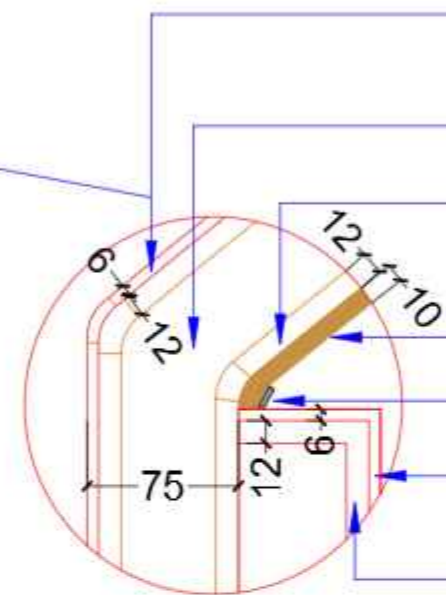

6MM VENEER FLUTES ON 12MM PLY BASE
 TV IN NICHE AS PER SELECTION
 6MM VENEER FLUTES ON 12MM PLY BASE

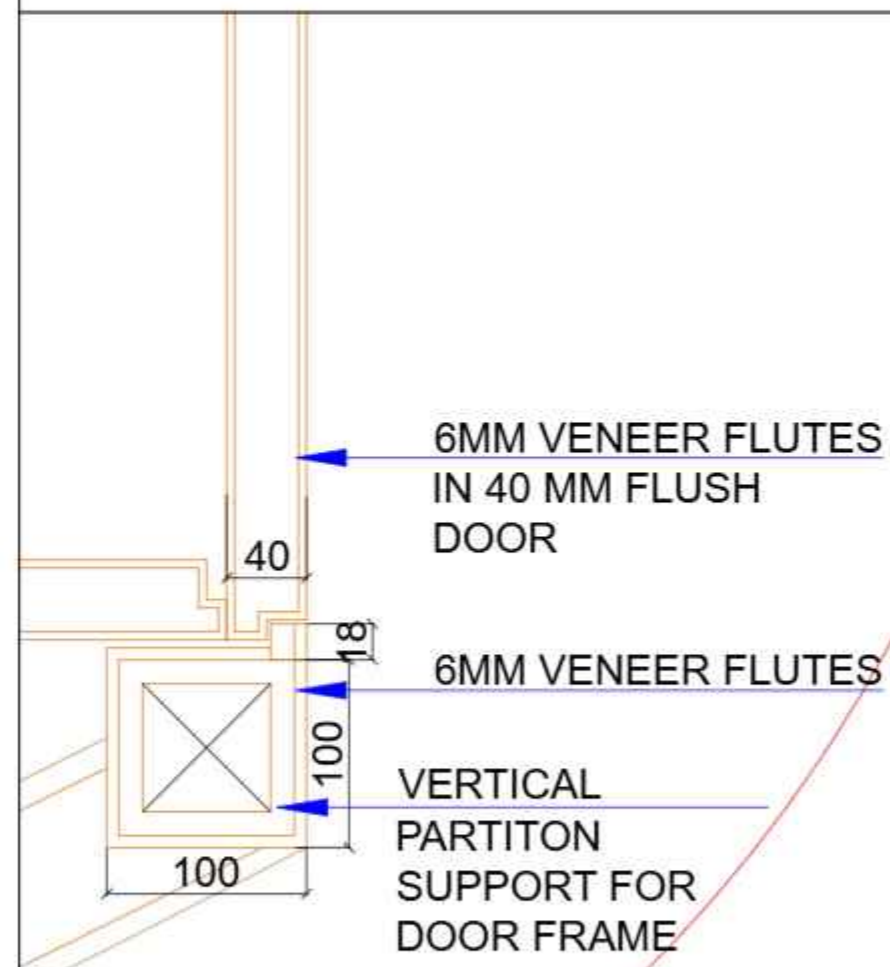

6MM VENEER FLUTES IN 40 MM FLUSH DOOR
 6MM VENEER FLUTES
 VERTICAL PARTITON SUPPORT FOR DOOR FRAME

DWG NO. SBI_LHO_PUNE_12TH_FL_WT_PLAN & DETAILS_07

NOTE:
THIS DRAWING IS THE SOLE PROPERTY OF 'METAPHORS'.
IT MUST NOT BE COPIED OR REPRODUCED IN ANYWAY OR
MADE ACCESSIBLE TO THIRD PARTY WITHOUT THE
WRITTEN APPROVAL OF THE OWNER.

LEGEND

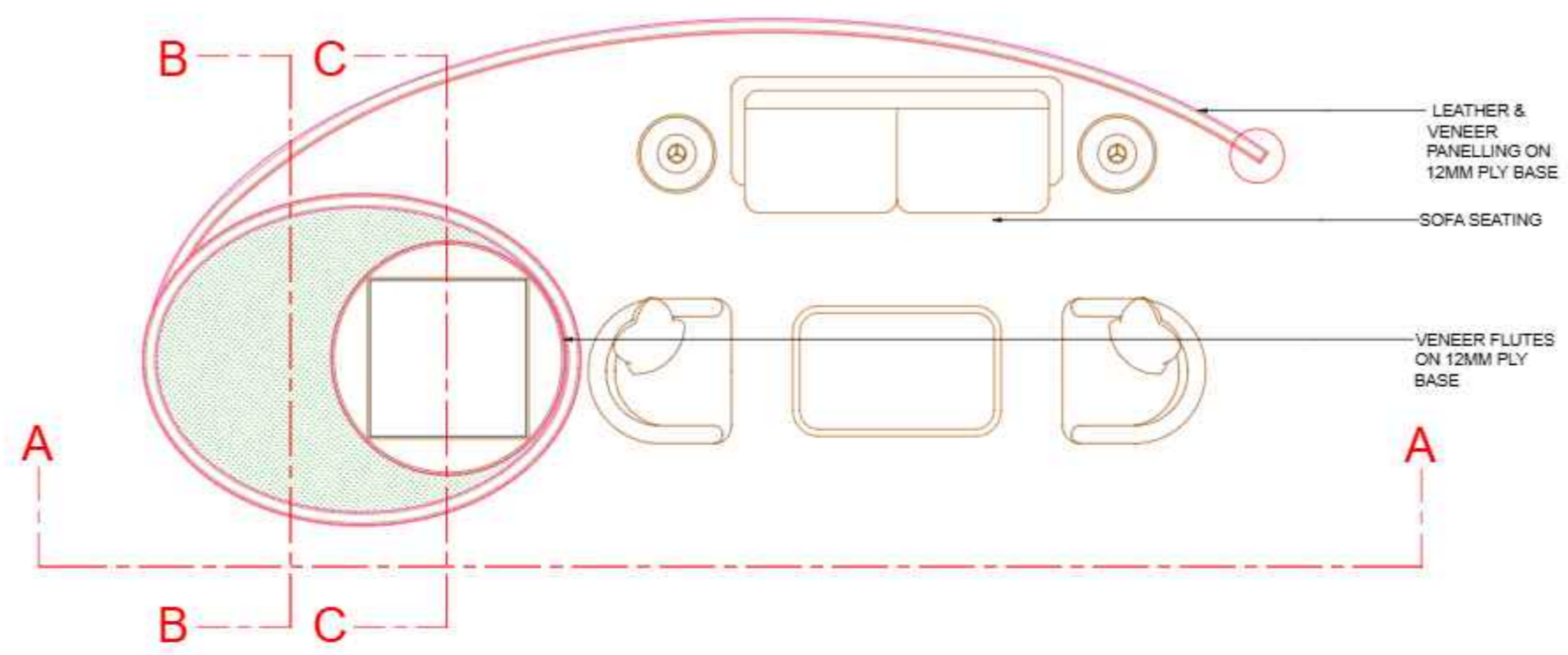

NOTE:
ALL DIMENSIONS ARE IN MM.
DO NOT SCALE THE DRAWING. ONLY WRITTEN DIMENSIONS TO BE
CONSIDERED.
ANY DISCREPANCY IN THE DRAWING SHALL BE BROUGHT TO NOTICE TO
ARCHITECT PRIOR TO EXECUTION.
THIS DRAWING IS PROPERTY OF ARCHITECT AND SHALL NOT BE
REPRODUCED OR USED WITHOUT EXPLICIT PERMISSION OF ARCHITECT
FOR STRUCTURAL DETAIL. REFER R.O.C. CONSULTANT'S DRAWING.

PROJECT NAME:

SBI-LHO, PUNE

DRAWING TITLE:

SBI_LHO_PUNE_12TH.FLOOR_WAITING
AREA_PLAN & DETAILS

DATE: 27.12.2024

REV	DATE	DESCRIPTION
1	27-12-2024	AS PER SITE MEASUREMENTS

CONSULTANTS	
M.E.P. -	
Landscape -	
SCALE	R.O.C. -
N.T.S.	

ARCHITECT'S STAMP & SIGNATURE

DRAWN BY: SHIKHA CHK BY: PM

ARCHITECT:



© 2023, Metaphors Architects, All Rights Reserved. Contact: Metaphors Architects, Pune, India.
Phone: +91-20-28875113 Fax: +91-20-28875114 Email: info@metaphorsdesign.com
Website: www.metaphorsdesign.com

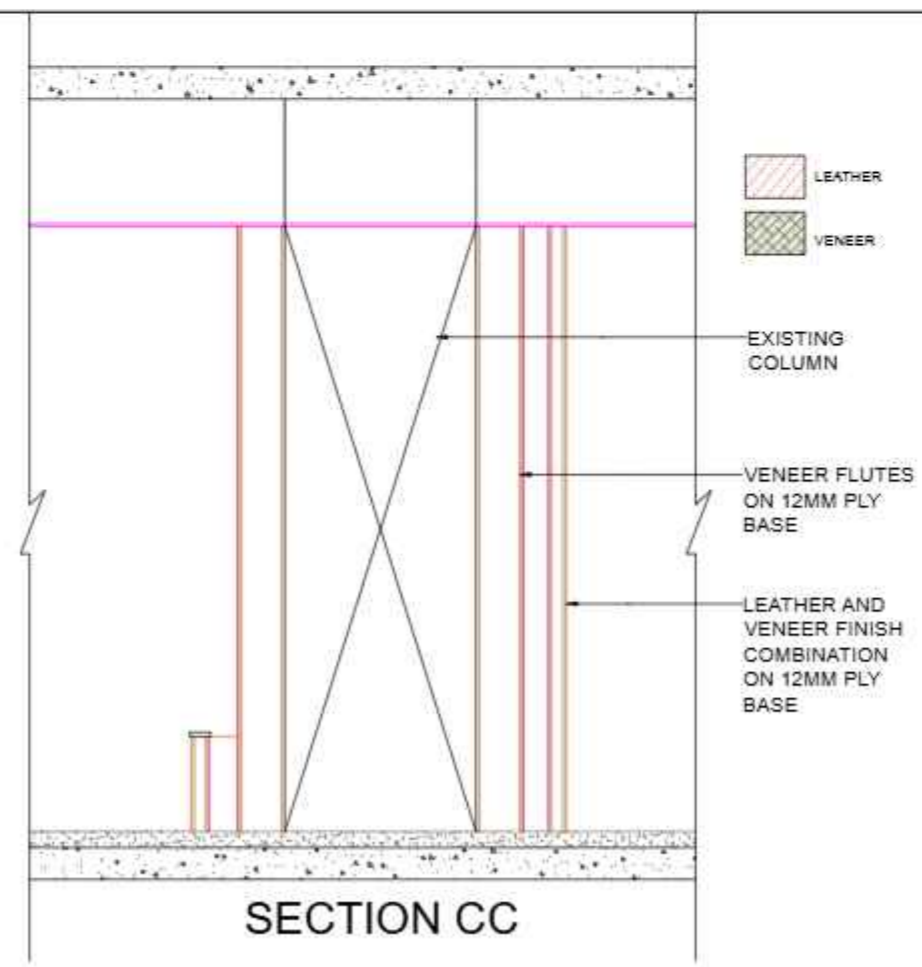

SECTION CC

DETAIL A

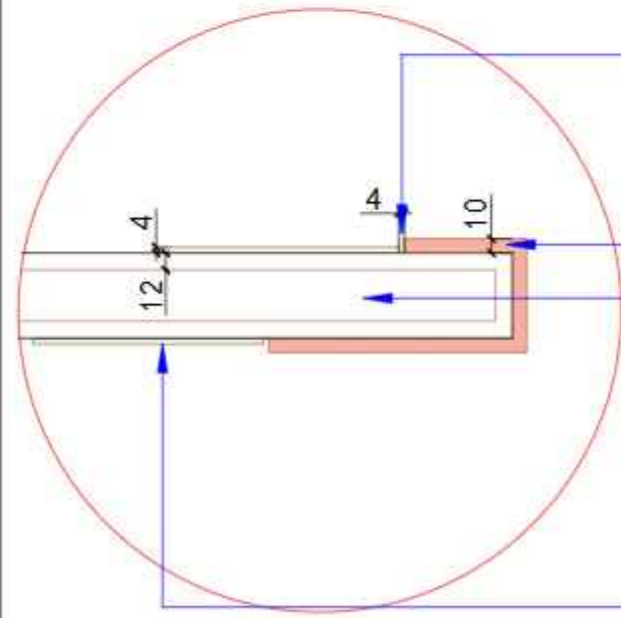

4MM GROOVE IN
VENEER

10 MM LEATHER
PANELLING ON 12
MM PLY BASE



ALLUMINIUM
SECTIONS WITH PLY
SUPPORT

4 MM LEATHER
PANELLING ON 12
MM PLY BASE

DWG NO. SBI_LHO_PUNE_12TH_FL_WT_ELEVATION_08

NOTES:
THIS DRAWING IS THE SOLE PROPERTY OF 'METAPHORS'.
IT MUST NOT BE COPIED OR REPRODUCED IN ANYWAY OR
MADE ACCESSIBLE TO THIRD PARTY WITHOUT THE
WRITTEN APPROVAL OF THE OWNER.

LEGEND

-  LEATHER
-  VENEER

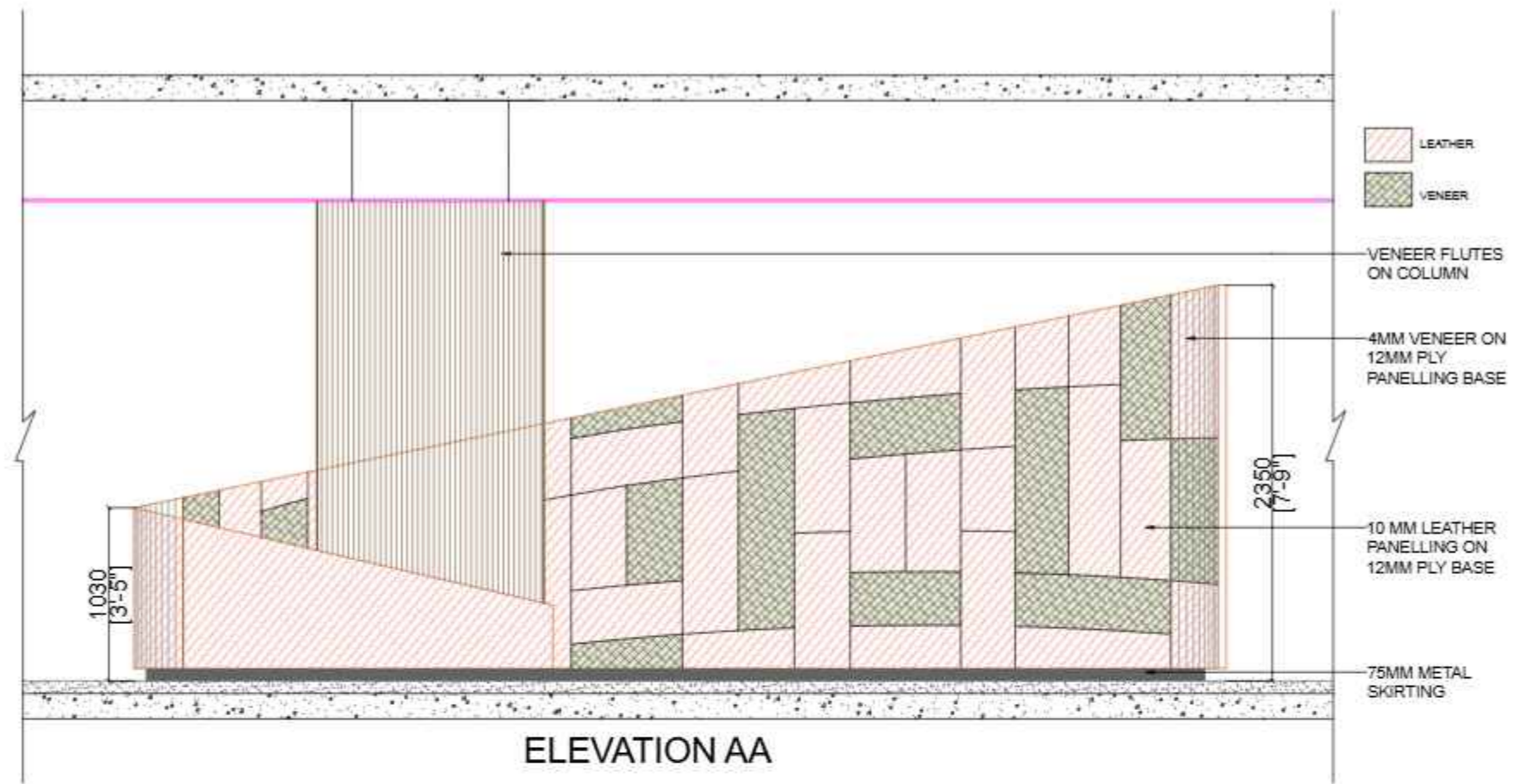

ELEVATION AA

NOTE:
ALL DIMENSIONS ARE IN MM.
DO NOT SCALE THE DRAWING. ONLY WRITTEN DIMENSIONS TO BE
CONSIDERED.
ANY DISCREPANCY IN THE DRAWING SHALL BE BROUGHT TO NOTICE TO
ARCHITECT PRIOR TO EXECUTION.
THIS DRAWING IS PROPERTY OF ARCHITECT AND SHALL NOT BE
REPRODUCED OR USED WITHOUT EXPLICIT PERMISSION OF ARCHITECT
FOR STRUCTURAL DETAIL, REFER R.O.C. CONSULTANT'S DRAWING.

PROJECT NAME:

SBI-LHO, PUNE

DRAWING TITLE:

SBI_LHO_PUNE_12TH.FLOOR_WAITING
AREA_SECTIONS

DATE: 27.12.2024

REV	DATE	DESCRIPTION
1	27-12-2024	AS PER SITE MEASUREMENTS



CONSULTANTS	
M.E.P. -	
Landscape -	
SCALE	R.O.C. -
N.T.S.	

ARCHITECT'S STAMP & SIGNATURE

DRAWN BY: SHIKHA CHK BY: PM

ARCHITECT:
 **etaphors**
ARCHITECTS & DESIGNERS

© 2024, PUNE (INDIA) BRANCH, 47 BANGALORE ROAD, COLONY (INDIA) PUNE 411 006, INDIA
Phone: +91-20-28877513 Fax: +91-20-28877512 Email: info@metaphorsdesign.com
Website: www.metaphorsdesign.com

-  10 MM LEATHER PANELLING ON
12 MM PLY BASE
-  4 MM VENEER PANELLING ON
12 MM PLY BASE

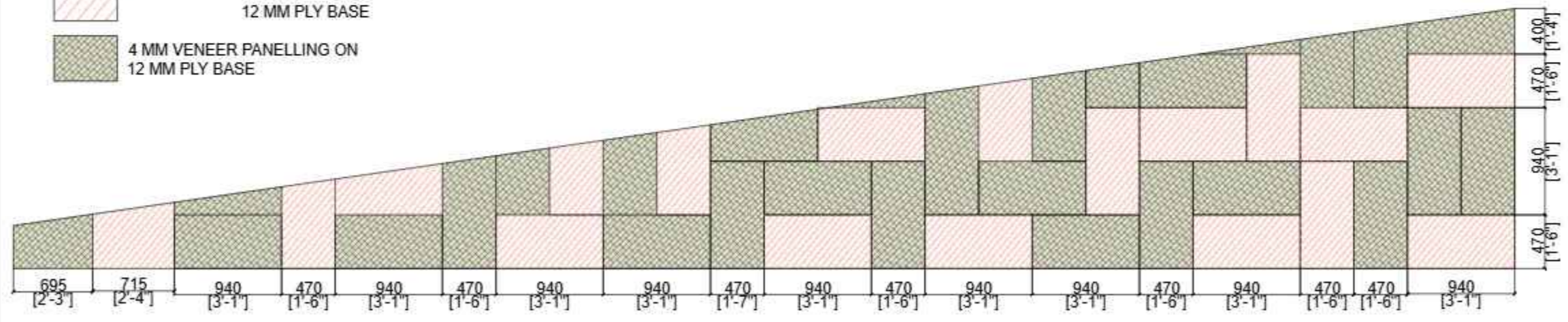

UNFOLDED ELEVATION

DWG NO. SBI_LHO_PUNE_12TH_FL_GM.CB.1_FUR_LAYOUT_09

NOTES:
 THIS DRAWING IS THE SOLE PROPERTY OF 'METAPHORS'.
 IT MUST NOT BE COPIED OR REPRODUCED IN ANYWAY OR
 MADE ACCESSIBLE TO THIRD PARTY WITHOUT THE
 WRITTEN APPROVAL OF THE OWNER.

LEGEND

NOTE:
 ALL DIMENSIONS ARE IN MM.
 DO NOT SCALE THE DRAWING. ONLY WRITTEN DIMENSIONS TO BE
 CONSIDERED.
 ANY DISCREPANCY IN THE DRAWING SHALL BE BROUGHT TO NOTICE TO
 ARCHITECT PRIOR TO EXECUTION.
 THIS DRAWING IS PROPERTY OF ARCHITECT AND SHALL NOT BE
 REPRODUCED OR USED WITHOUT EXPLICIT PERMISSION OF ARCHITECT
 FOR STRUCTURAL DETAIL, REFER R.C.C. CONSULTANT'S DRAWING.

PROJECT NAME:
 SBI-LHO, PUNE

DRAWING TITLE:
 SBI_LHO_PUNE_12TH.FLOOR_GM CABIN
 1_FURNITURE LAYOUT

DATE: 22.10.2024

REV	DATE	DESCRIPTION
1	27-12-2024	AS PER SITE MEASUREMENTS

CONSULTANTS
 M.E.P. -
 Landscape -
 SCALE
 N.T.S.
 R.C.C. -

ARCHITECT'S STAMP & SIGNATURE

DRAWN BY: SHIKHA CHK BY: PM

ARCHITECT:

 etaphors
 Architects & Designers

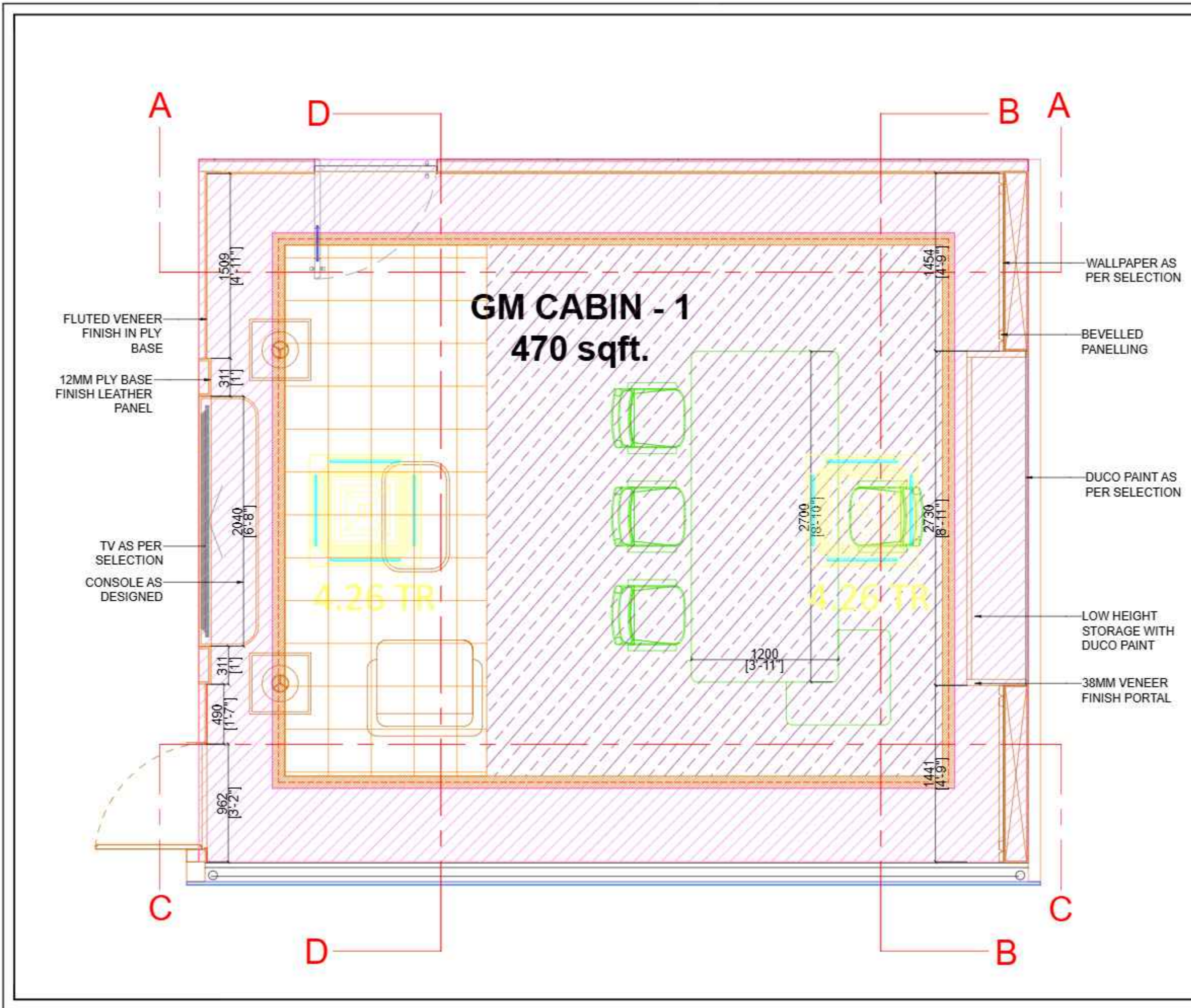
© 2024, Metaphors Architects & Designers, All Rights Reserved. Contact: Metaphors Architects & Designers, Pune
 Phone: +91-20-28877543 Fax: +91-20-28877543 Email: info@metaphorsdesign.com
 Website: www.metaphorsdesign.com



DWG NO. SBI_LHO_PUNE_12TH_FL_GM.CB.1_FUR_LAYOUT_10

NOTES:
THIS DRAWING IS THE SOLE PROPERTY OF 'META'PHORS'.
IT MUST NOT BE COPIED OR REPRODUCED IN ANYWAY OR
MADE ACCESSIBLE TO THIRD PARTY WITHOUT THE
WRITTEN APPROVAL OF THE OWNER.

LEGEND

NOTE:
ALL DIMENSIONS ARE IN MM.
DO NOT SCALE THE DRAWING. ONLY WRITTEN DIMENSIONS TO BE
CONSIDERED.
ANY DISCREPANCY IN THE DRAWING SHALL BE BROUGHT TO NOTICE TO
ARCHITECT PRIOR TO EXECUTION.
THIS DRAWING IS PROPERTY OF ARCHITECT AND SHALL NOT BE
REPRODUCED OR USED WITHOUT EXPLICIT PERMISSION OF ARCHITECT.
FOR STRUCTURAL DETAIL, REFER R.O.C. CONSULTANT'S DRAWING.

PROJECT NAME:

SBI-LHO, PUNE

DRAWING TITLE:

SBI_LHO_PUNE_12TH.FLOOR_GM CABIN 1
_ SECTIONS

DATE: 22.10.2024

REV	DATE	DESCRIPTION
1	27-12-2024	AS PER SITE MEASUREMENTS

CONSULTANTS	
M.E.P. -	
Landscape -	
SCALE	R.O.C. -
N.T.S.	

ARCHITECT'S STAMP & SIGNATURE:

DRAWN BY: SHIKHA CHK BY: PM

ARCHITECT:



© 2024. All Rights Reserved. All Rights Reserved. Contact: 020-26111111, 020-26111111
Phone: +91-20-26111111 Fax: +91-20-26111111 Email: info@metaphorsdesign.com
Website: www.metaphorsdesign.com

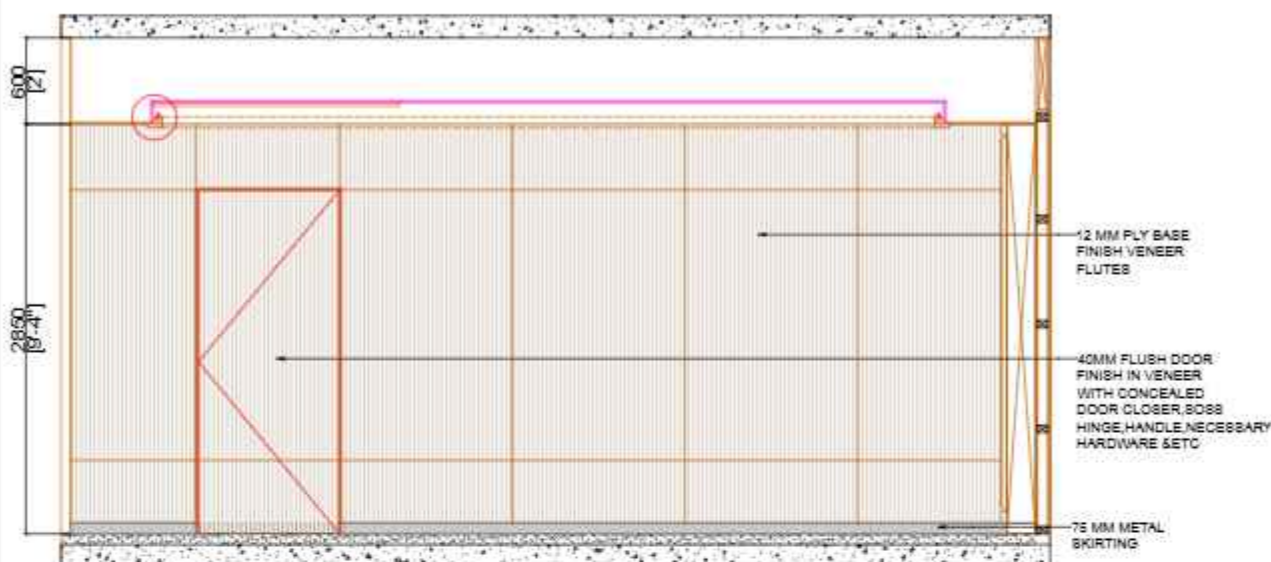

SECTION AA

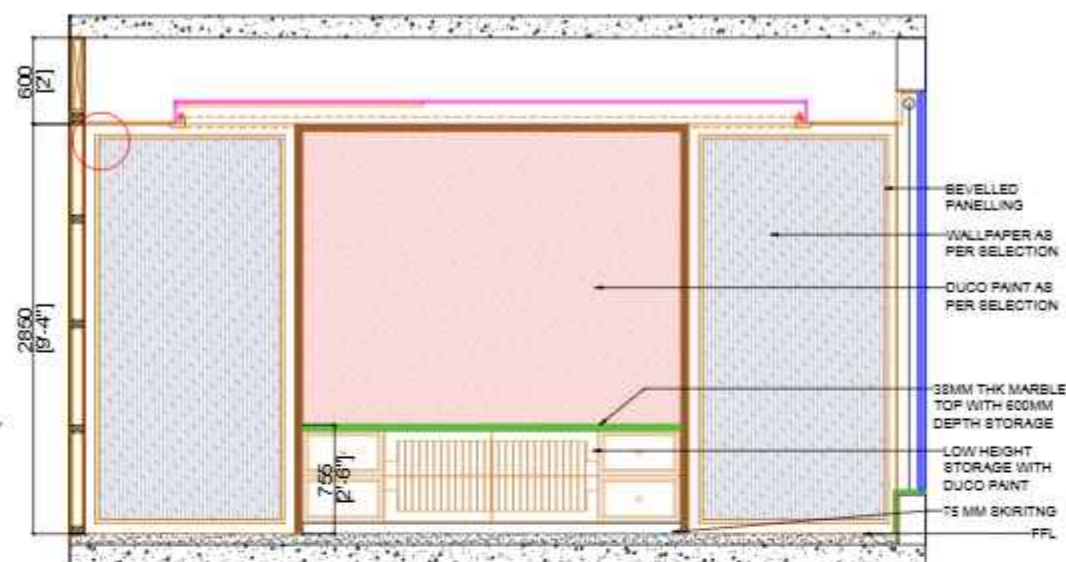

SECTION BB

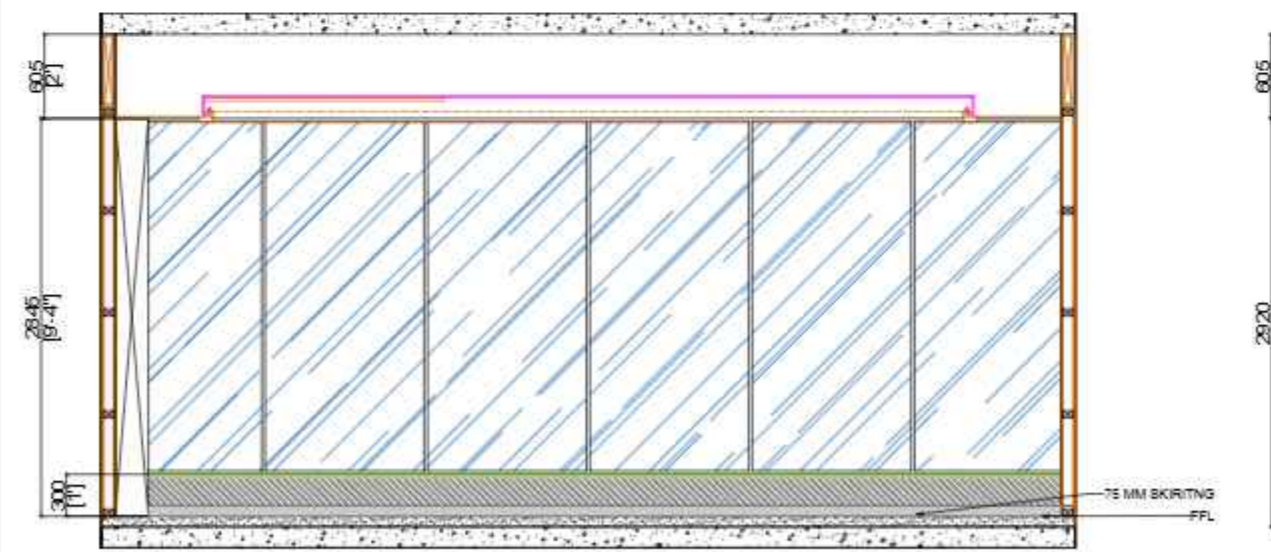

SECTION CC

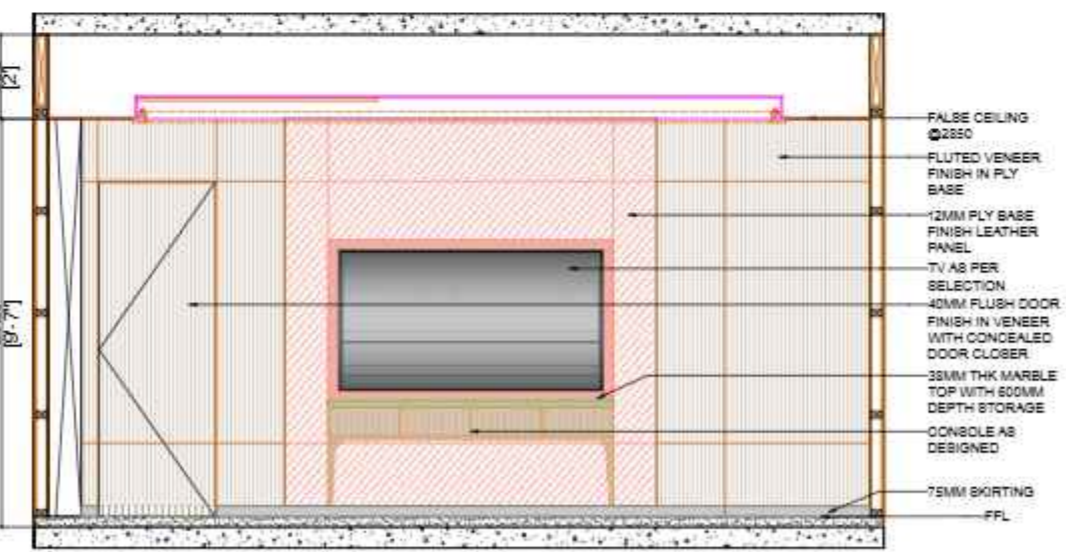

SECTION DD

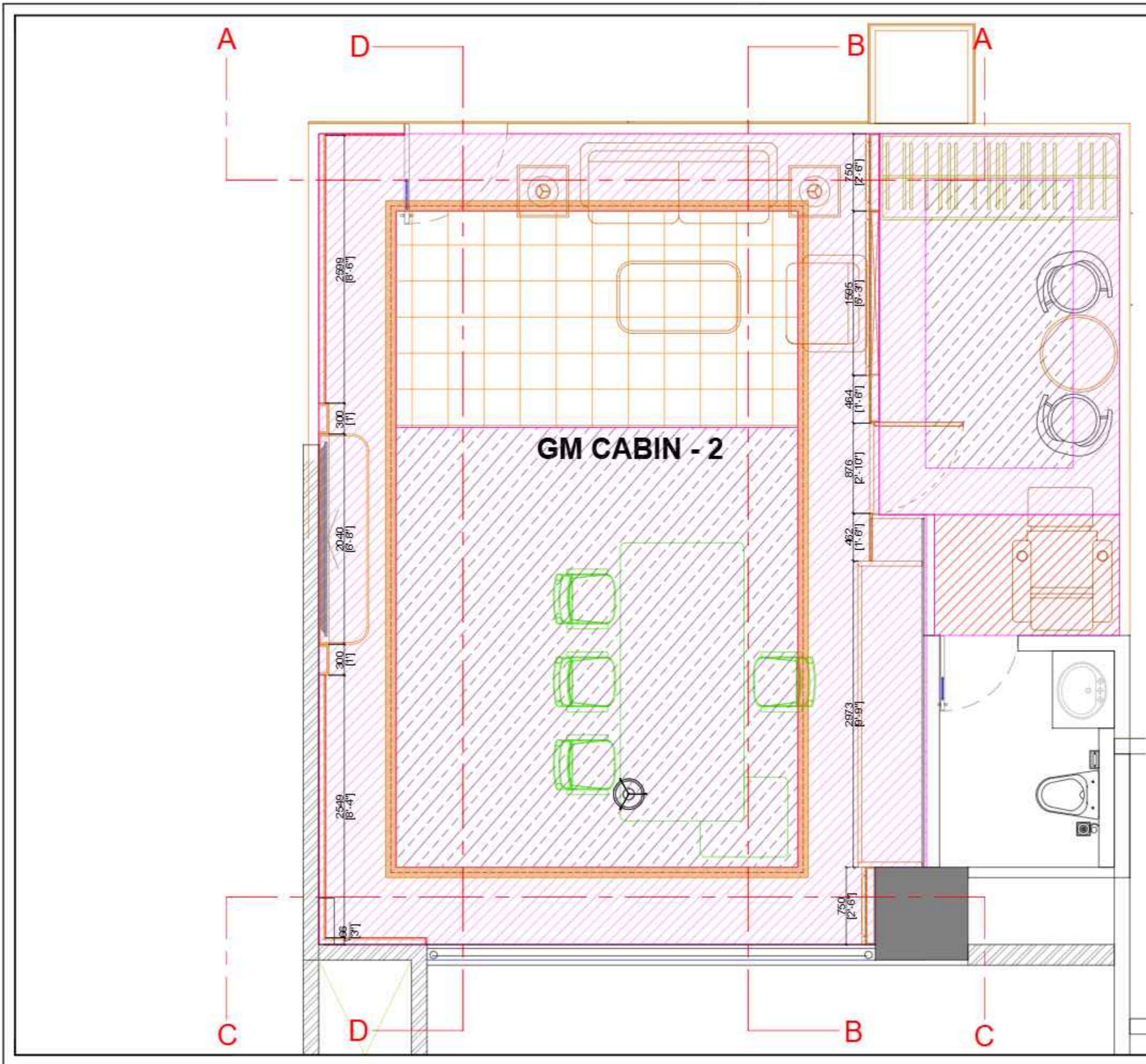

DWG NO.	SBI_LHO_PUNE_12TH.FL_GM.CB.2_FUR.LAYOUT_11	
NOTES:	THIS DRAWING IS THE SOLE PROPERTY OF 'METAPHORS'. IT MUST NOT BE COPIED OR REPRODUCED IN ANYWAY OR MADE ACCESSIBLE TO THIRD PARTY WITHOUT THE WRITTEN APPROVAL OF THE OWNER.	
LEGEND		
NOTE: ALL DIMENSIONS ARE IN MM. DO NOT SCALE THE DRAWING. ONLY WRITTEN DIMENSIONS TO BE CONSIDERED. ANY DISCREPANCY IN THE DRAWING SHALL BE BROUGHT TO NOTICE TO ARCHITECT PRIOR TO EXECUTION. THIS DRAWING IS PROPERTY OF ARCHITECT AND SHALL NOT BE REPRODUCED OR USED WITHOUT EXPLICIT PERMISSION OF ARCHITECT FOR STRUCTURAL DETAIL. REFER R.C.C. CONSULTANT'S DRAWING.		
PROJECT NAME:		
SBI-LHO, PUNE		
DRAWING TITLE:		
SBI_LHO_PUNE_12TH.FLOOR_GM CABIN-2_FURNITURE LAYOUT		
DATE: 22.10.2024		
REV	DATE	DESCRIPTION
1	27-12-2024	AS PER SITE MEASUREMENTS
CONSULTANTS		
M.E.P. -		
Landscape -		
SCALE		
N.T.S.		
R.O.C. -		
ARCHITECT'S STAMP & SIGNATURE		
DRAWN BY:	SHIKHA	CHK BY: PM
ARCHITECT:		
 etaphors architects & designers		
<small>© 2023, Plot: Guna, Sector: 47, Baner, Pune, Maharashtra. Phone: +91-20-28875113. Fax: +91-20-28875112. Email: info@metaphorsdesign.com. Website: www.metaphorsdesign.com</small>		

NOTE:
THIS DRAWING IS THE SOLE PROPERTY OF 'METAPHORS'.
IT MUST NOT BE COPIED OR REPRODUCED IN ANYWAY OR
MADE ACCESSIBLE TO THIRD PARTY WITHOUT THE
WRITTEN APPROVAL OF THE OWNER.

LEGEND

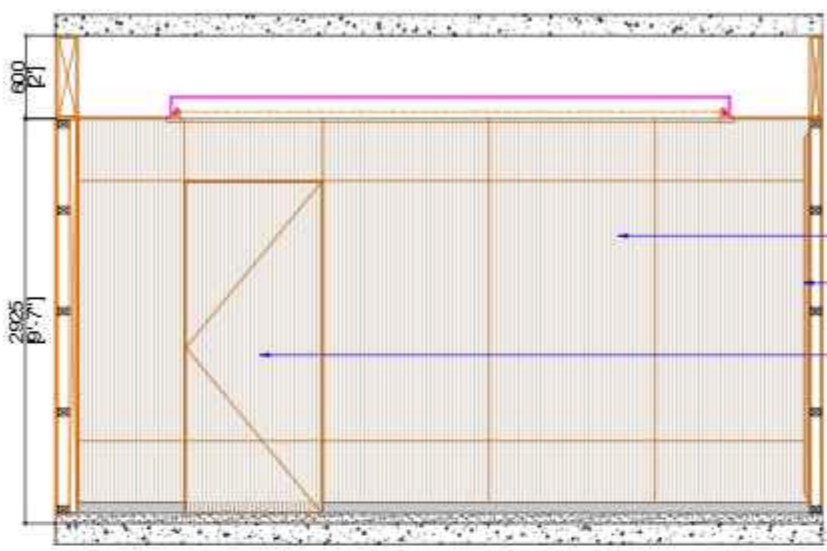

SECTION A

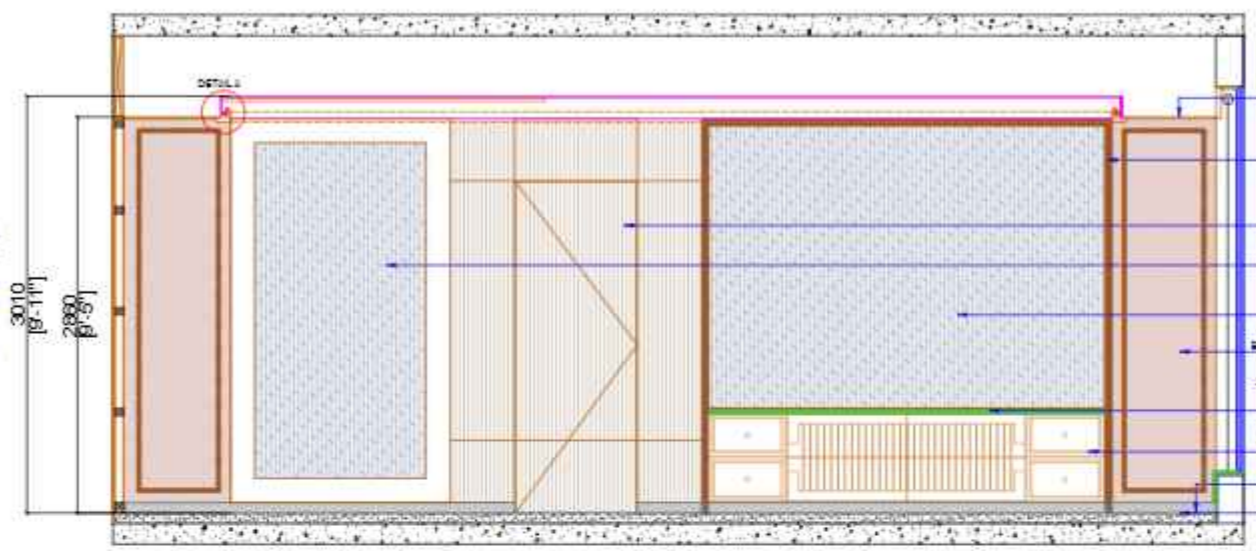

SECTION B

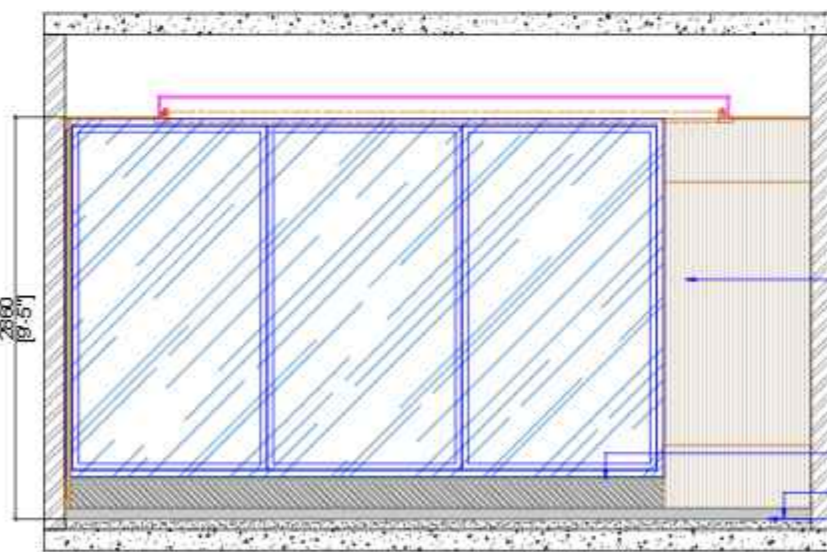

SECTION C

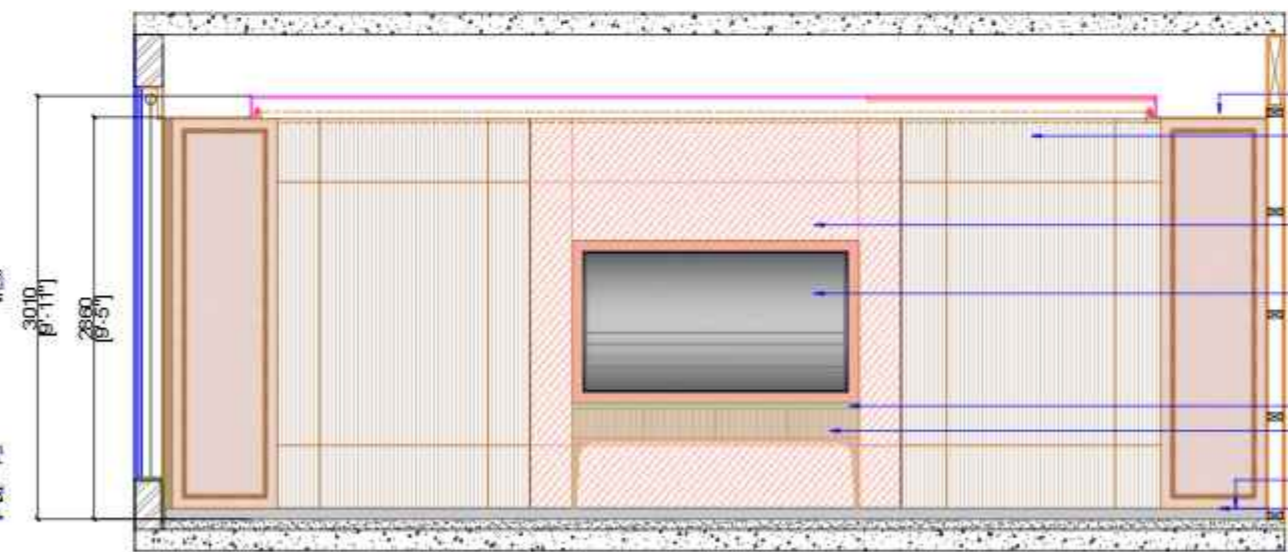

SECTION D

NOTE:
ALL DIMENSIONS ARE IN MM.
DO NOT SCALE THE DRAWING. ONLY WRITTEN DIMENSIONS TO BE CONSIDERED.
ANY DISCREPANCY IN THE DRAWING SHALL BE BROUGHT TO NOTICE TO ARCHITECT PRIOR TO EXECUTION.
THIS DRAWING IS PROPERTY OF ARCHITECT AND SHALL NOT BE REPRODUCED OR USED WITHOUT EXPLICIT PERMISSION OF ARCHITECT FOR STRUCTURAL DETAIL, REFER R.C.C. CONSULTANT'S DRAWING.

PROJECT NAME:

SBI-LHO, PUNE

DRAWING TITLE:

SBI_LHO_PUNE_12TH.FLOOR_GM CABIN-2 SECTIONS

DATE: 22.10.2024

REV	DATE	DESCRIPTION
1	27-12-2024	AS PER SITE MEASUREMENTS

CONSULTANTS	
M.E.P. -	
Landscape -	
SCALE	R.O.C. -
N.T.S.	

ARCHITECT'S STAMP & SIGNATURE

DRAWN BY: SHIKHA CHK BY: PM

ARCHITECT:
metaphors
Architects & Designers

DETAIL B

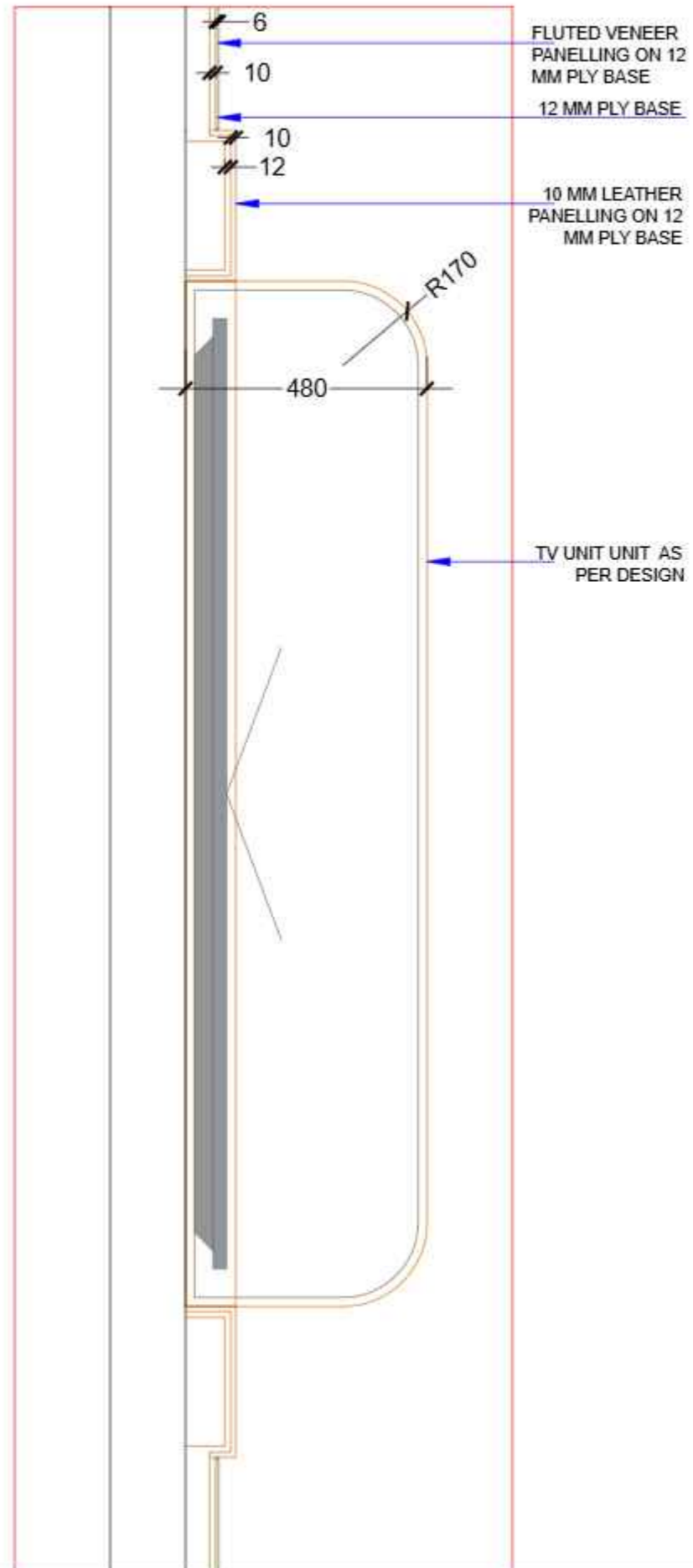

BEVELLED PANELLING DETAILS

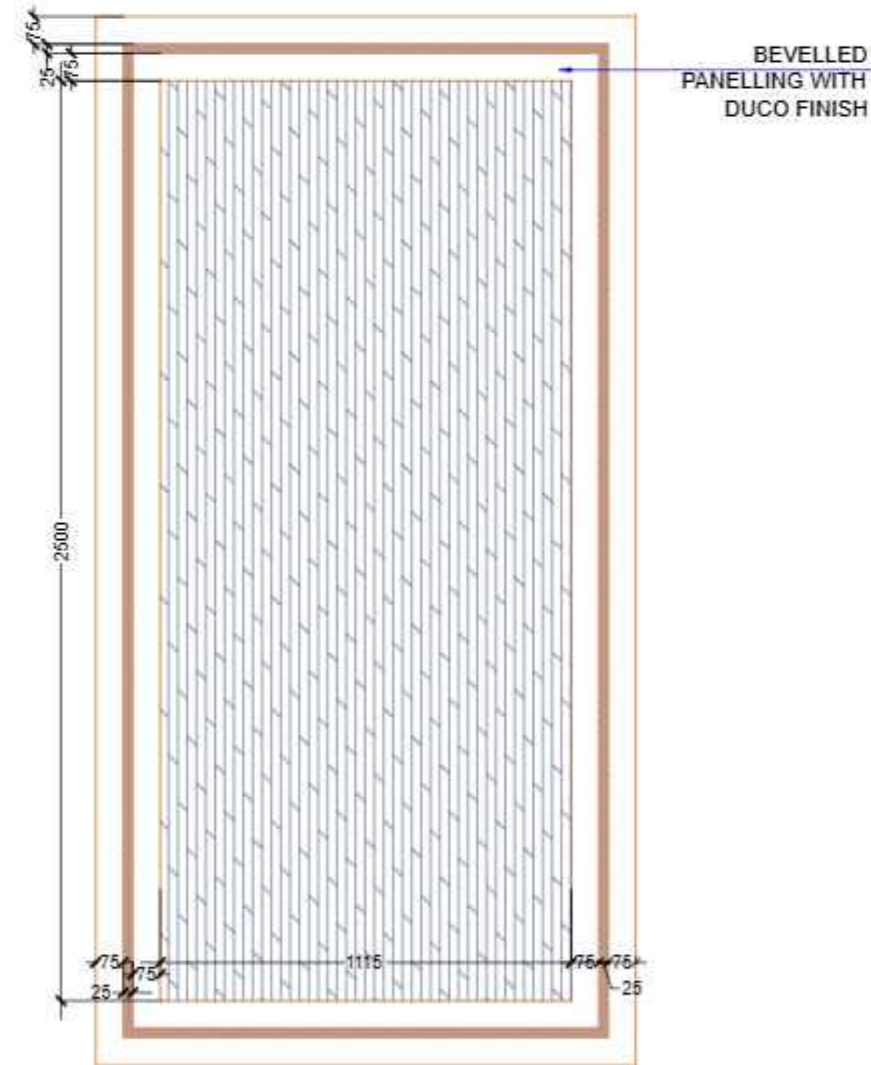
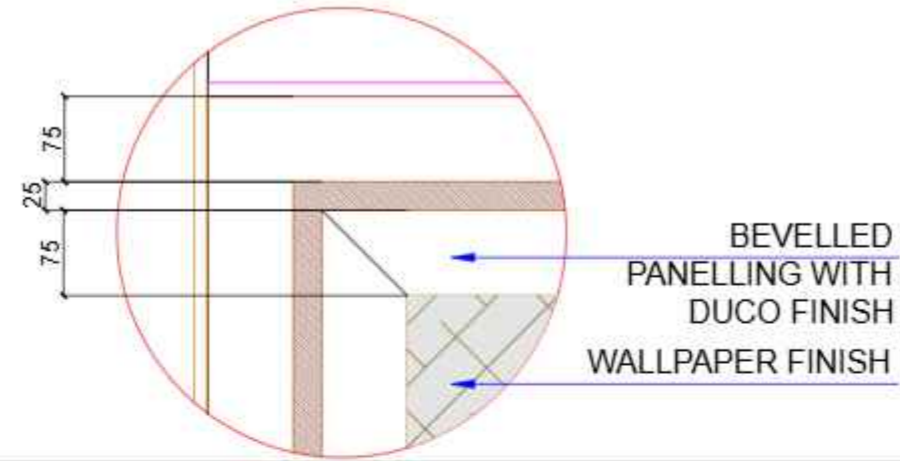

ELEVATION

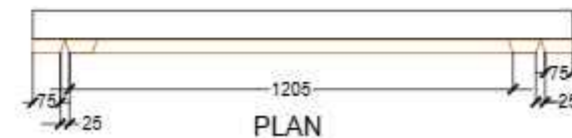

DWG NO.	SBI_LHO_PUNE_12TH.FL_GM.CB.2.FUR.DETAILS_13	
NOTES:	THIS DRAWING IS THE SOLE PROPERTY OF 'METAPHORS'. IT MUST NOT BE COPIED OR REPRODUCED IN ANYWAY OR MADE ACCESSIBLE TO THIRD PARTY WITHOUT THE WRITTEN APPROVAL OF THE OWNER.	
LEGEND		
<p>NOTE:</p> <p>ALL DIMENSIONS ARE IN MM.</p> <p>DO NOT SCALE THE DRAWING. ONLY WRITTEN DIMENSIONS TO BE CONSIDERED.</p> <p>ANY DISCREPANCY IN THE DRAWING SHALL BE BROUGHT TO NOTICE TO ARCHITECT PRIOR TO EXECUTION.</p> <p>THIS DRAWING IS PROPERTY OF ARCHITECT AND SHALL NOT BE REPRODUCED OR USED WITHOUT EXPLICIT PERMISSION OF ARCHITECT FOR STRUCTURAL DETAIL. REFER R.C.C. CONSULTANT'S DRAWING.</p>		
PROJECT NAME:		
SBI-LHO, PUNE		
DRAWING TITLE:		
SBI_LHO_PUNE_12TH.FLOOR_GM CABIN-2_FURNITURE DETAILS		
DATE: 22.10.2024		
REV	DATE	DESCRIPTION
1	27-12-2024	AS PER SITE MEASUREMENTS
<p>CONSULTANTS</p> <p>M.E.P. -</p> <p>Landscape -</p> <p>SCALE</p> <p>N.T.S.</p> <p>R.C.C. -</p>		
ARCHITECT'S STAMP & SIGNATURE:		
<p>DRAWN BY: SHIKHA</p> <p>ARCHITECT:</p> <p>etaphors metaphors architects & designers</p>	<p>CHK BY: PM</p>	
<p>© 2024, Metaphors Architects, All Rights Reserved. Contact: Metaphors Architects, Pune (INDIA), India. Phone: +91-20-28877511 Fax: +91-20-28877512 Email: info@metaphorsdesign.com Website: www.metaphorsdesign.com</p>		

DWG NO. SBI_LHO_PUNE_12TH_FL_PG_ELV & DETAILS_14

NOTES:
 THIS DRAWING IS THE SOLE PROPERTY OF 'METAPHORS'. IT MUST NOT BE COPIED OR REPRODUCED IN ANYWAY OR MADE ACCESSIBLE TO THIRD PARTY WITHOUT THE WRITTEN APPROVAL OF THE OWNER.

LEGEND

NOTE:
 ALL DIMENSIONS ARE IN MM.
 DO NOT SCALE THE DRAWING. ONLY WRITTEN DIMENSIONS TO BE CONSIDERED.
 ANY DISCREPANCY IN THE DRAWING SHALL BE BROUGHT TO NOTICE TO ARCHITECT PRIOR TO EXECUTION.
 THIS DRAWING IS PROPERTY OF ARCHITECT AND SHALL NOT BE REPRODUCED OR USED WITHOUT EXPLICIT PERMISSION OF ARCHITECT FOR STRUCTURAL DETAIL. REFER R.C.C. CONSULTANT'S DRAWING.

PROJECT NAME:
 SBI-LHO, PUNE

DRAWING TITLE:
 SBI_LHO_PUNE_12TH.FLOOR_PASSAGE_FURNITURE DETAILS

DATE: 22.10.2024

REV	DATE	DESCRIPTION
1	27-12-2024	AS PER SITE MEASUREMENTS

CONSULTANTS
 M.E.P. -
 Landscape -

SCALE
 N.T.S.

ARCHITECT'S STAMP & SIGNATURE

DRAWN BY: SHIKHA CHK BY: PM

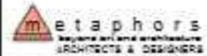
ARCHITECT:

 metaphors
 architects & designers

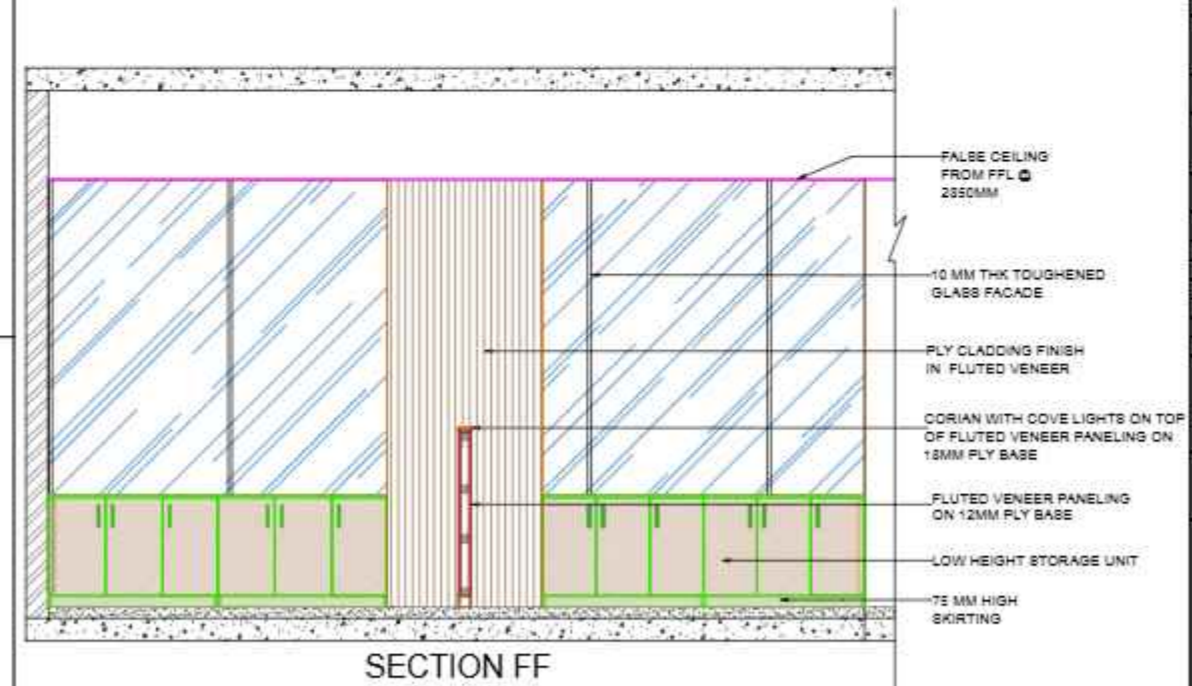
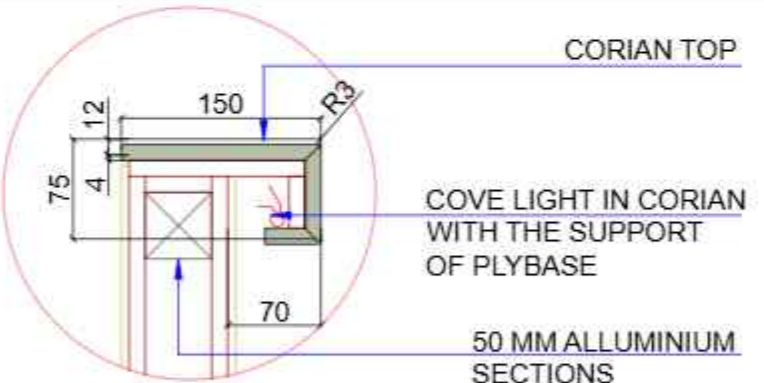
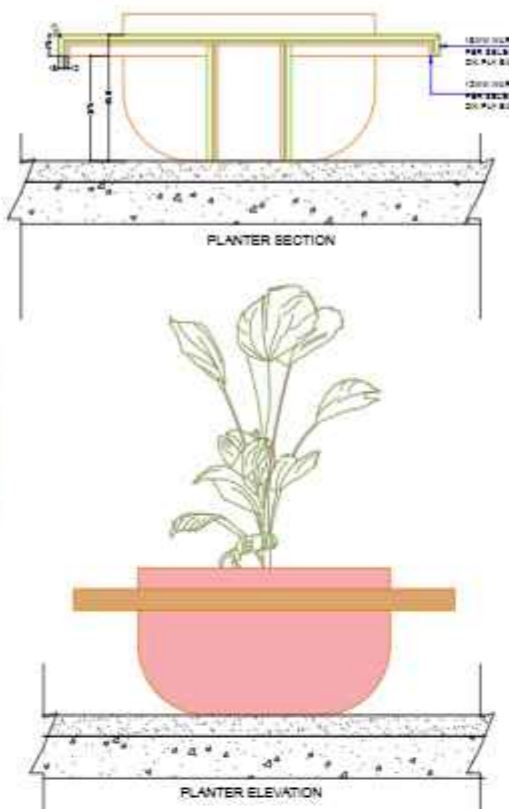
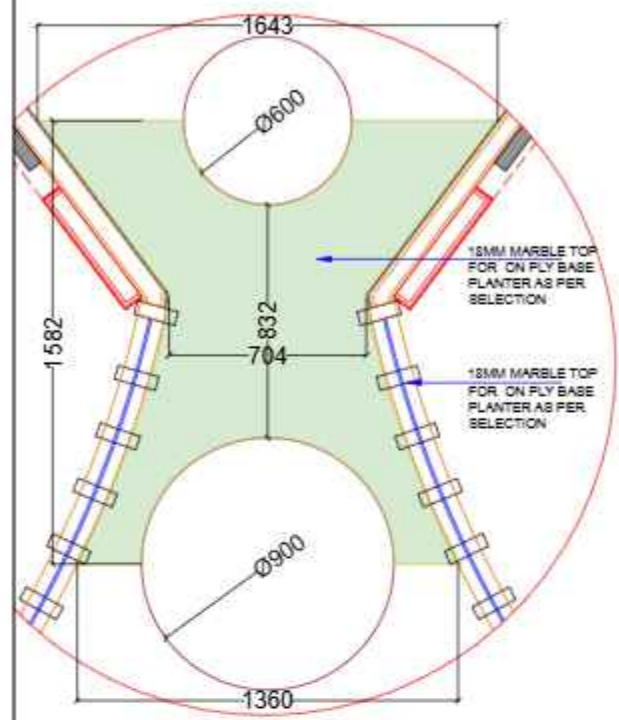
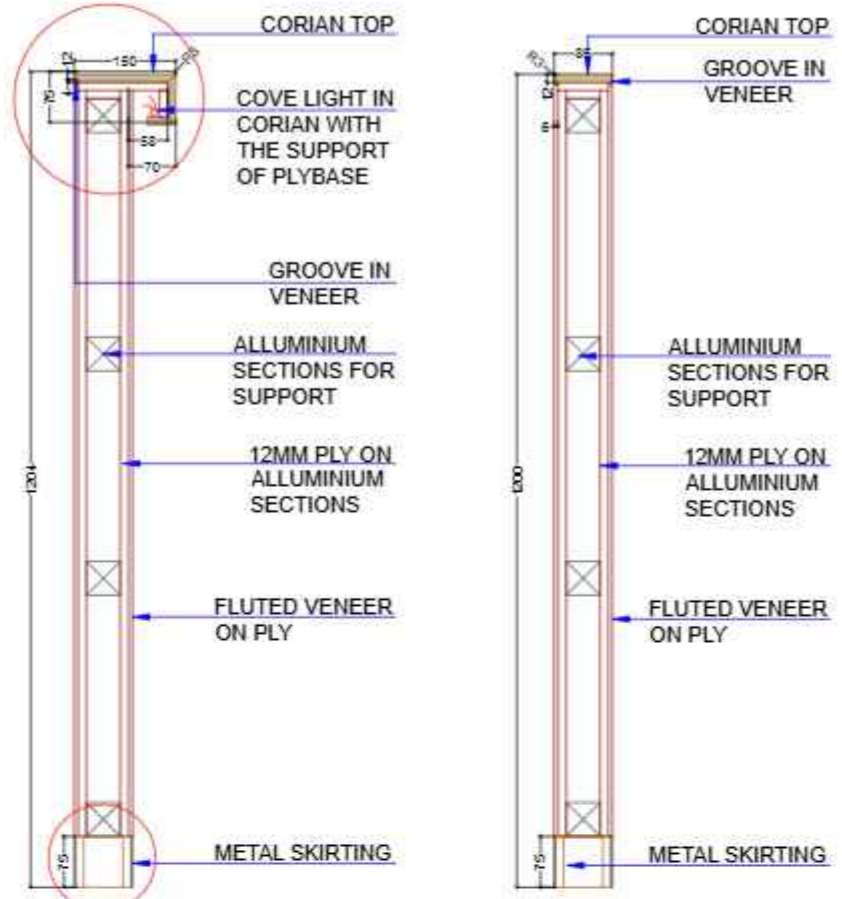
© 2024, Plot: LHO, Pune, Maharashtra, India. All Rights Reserved. For more information, please contact: Metaphors Architects & Designers, Plot: LHO, Pune, Maharashtra, India. Phone: +91-20-28875113 Fax: +91-20-28875114 Email: info@metaphorsdesign.com Website: www.metaphorsdesign.com



SECTION FF

DWG NO. SBI_LHO_PUNE_12TH_FL_ PG_SECTION_15

NOTES:
 THIS DRAWING IS THE SOLE PROPERTY OF 'E.T.A.P.H.O.R.S.'
 IT MUST NOT BE COPIED OR REPRODUCED IN ANYWAY OR
 MADE ACCESSIBLE TO THIRD PARTY WITHOUT THE
 WRITTEN APPROVAL OF THE OWNER.

LEGEND

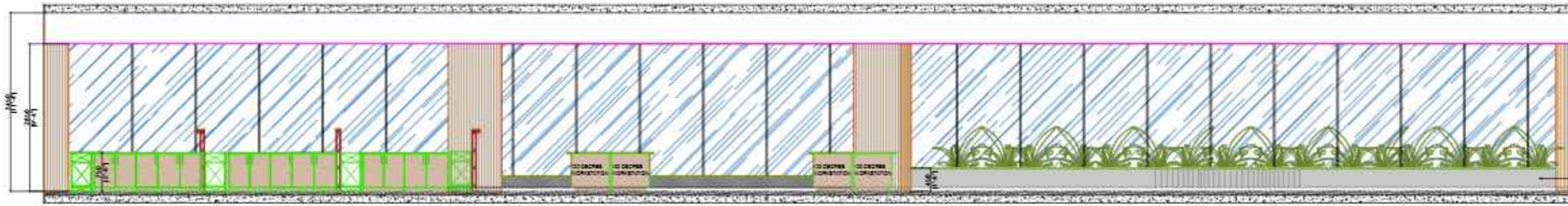
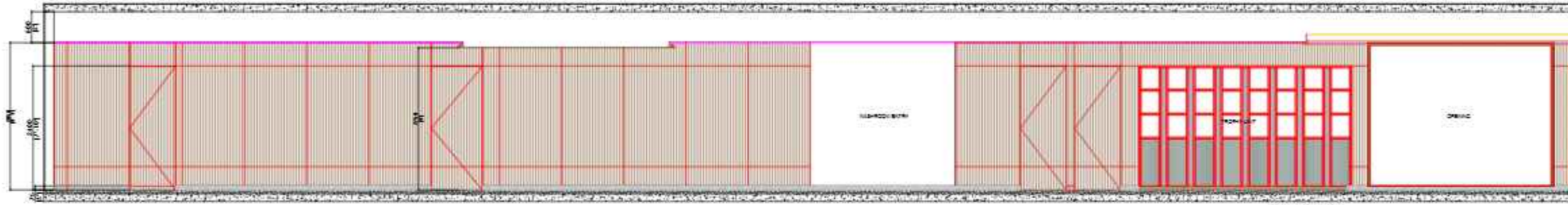

NOTE:
 ALL DIMENSIONS ARE IN MM.
 DO NOT SCALE THE DRAWING. ONLY WRITTEN DIMENSIONS TO BE
 CONSIDERED.
 ANY DISCREPANCY IN THE DRAWING SHALL BE BROUGHT TO NOTICE TO
 ARCHITECT PRIOR TO EXECUTION.
 THIS DRAWING IS PROPERTY OF ARCHITECT AND SHALL NOT BE
 REPRODUCED OR USED WITHOUT EXPLICIT PERMISSION OF ARCHITECT
 FOR STRUCTURAL DETAIL, REFER R.C.C. CONSULTANT'S DRAWING.

PROJECT NAME:

SBI-LHO, PUNE

DRAWING TITLE:

SBI_LHO_PUNE_12TH.FLOOR_PASSAGE SECTIONS

DATE: 22.10.2024

REV	DATE	DESCRIPTION
1	27-12-2024	AS PER SITE MEASUREMENTS

CONSULTANTS	
M.E.P. -	
Landscape -	
SCALE N.T.S.	R.C.C. -

ARCHITECT'S STAMP & SIGNATURE

DRAWN BY: SHIKHA CHK BY: PM

ARCHITECT:

 Architects & Designers

© 2024. All Rights Reserved. All Services Except Pune, Gurgaon (Regd. Office).
 Pune: +91-20-28870113 Fax: +91-20-28870114 Email: info@etaphorsdesign.com
 Website: www.etaphorsdesign.com

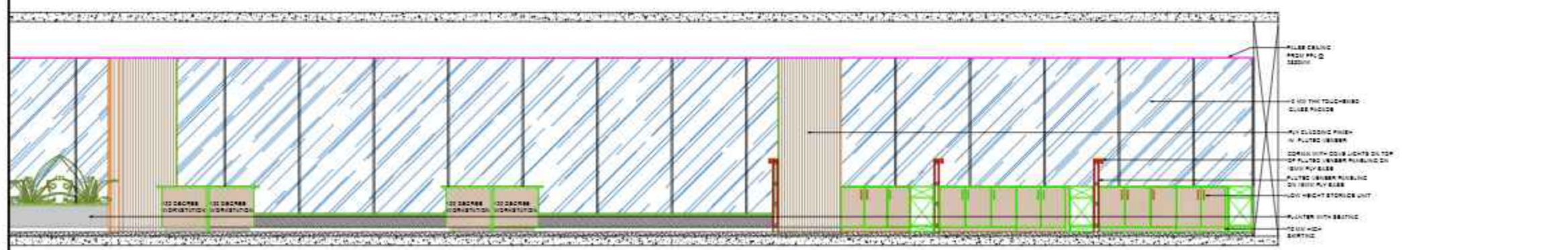
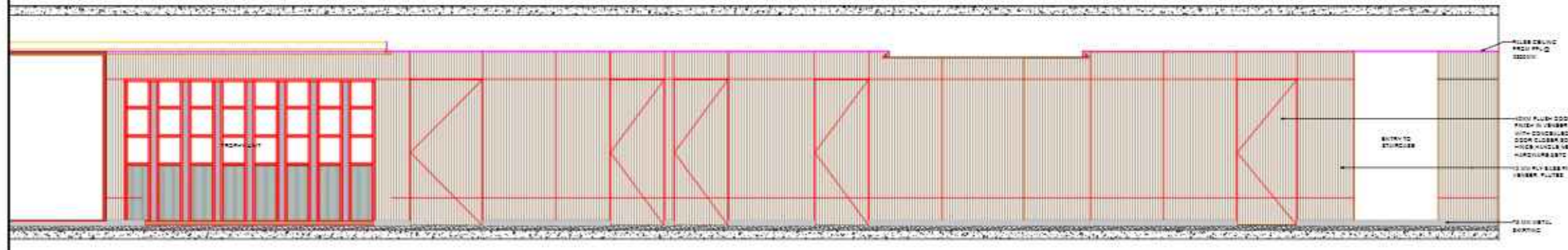

DWG NO: SBI_LHO_PUNE_12TH_FL_PG_SECTION_16

NOTES:
THIS DRAWING IS THE SOLE PROPERTY OF 'METAPHORS'. IT MUST NOT BE COPIED OR REPRODUCED IN ANYWAY OR MADE ACCESSIBLE TO THIRD PARTY WITHOUT THE WRITTEN APPROVAL OF THE OWNER.

LEGEND

NOTE:
ALL DIMENSIONS ARE IN MM.
DO NOT SCALE THE DRAWING. ONLY WRITTEN DIMENSIONS TO BE CONSIDERED.
ANY DISCREPANCY IN THE DRAWING SHALL BE BROUGHT TO NOTICE TO ARCHITECT PRIOR TO EXECUTION.
THIS DRAWING IS PROPERTY OF ARCHITECT AND SHALL NOT BE REPRODUCED OR USED WITHOUT EXPLICIT PERMISSION OF ARCHITECT FOR STRUCTURAL DETAIL, REFER R.O.C. CONSULTANT'S DRAWING.

PROJECT NAME:
SBI-LHO, PUNE

DRAWING TITLE:
SBI_LHO_PUNE_12TH.FLOOR_PASSAGE SECTIONS

DATE: 22.10.2024

REV	DATE	DESCRIPTION
1	27-12-2024	AS PER SITE MEASUREMENTS

CONSULTANTS
M.E.P. -
Landscape -
SCALE
N.T.S.
R.O.C. -

ARCHITECT'S STAMP & SIGNATURE

DRAWN BY: SHIKHA CHK BY: PM

ARCHITECT:
metaphors
Interior and Landscape Architecture
ARCHITECTS & DESIGNERS

© 2024, Maharashtra Bureau of Applied Research, Central Intra-Pune (CIP) Ltd. India
Phone: +91-20-28875113 Fax: +91-20-28875112 Email: info@metaphorsdesign.com
Website: www.metaphorsdesign.com

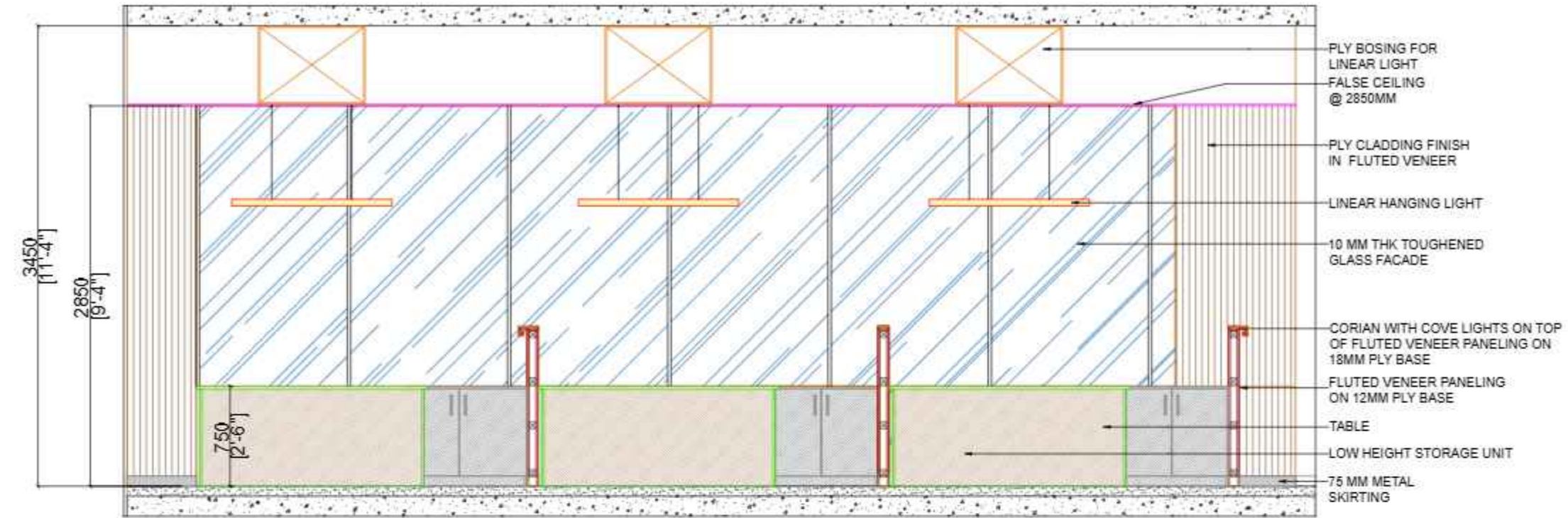

SECTION BB

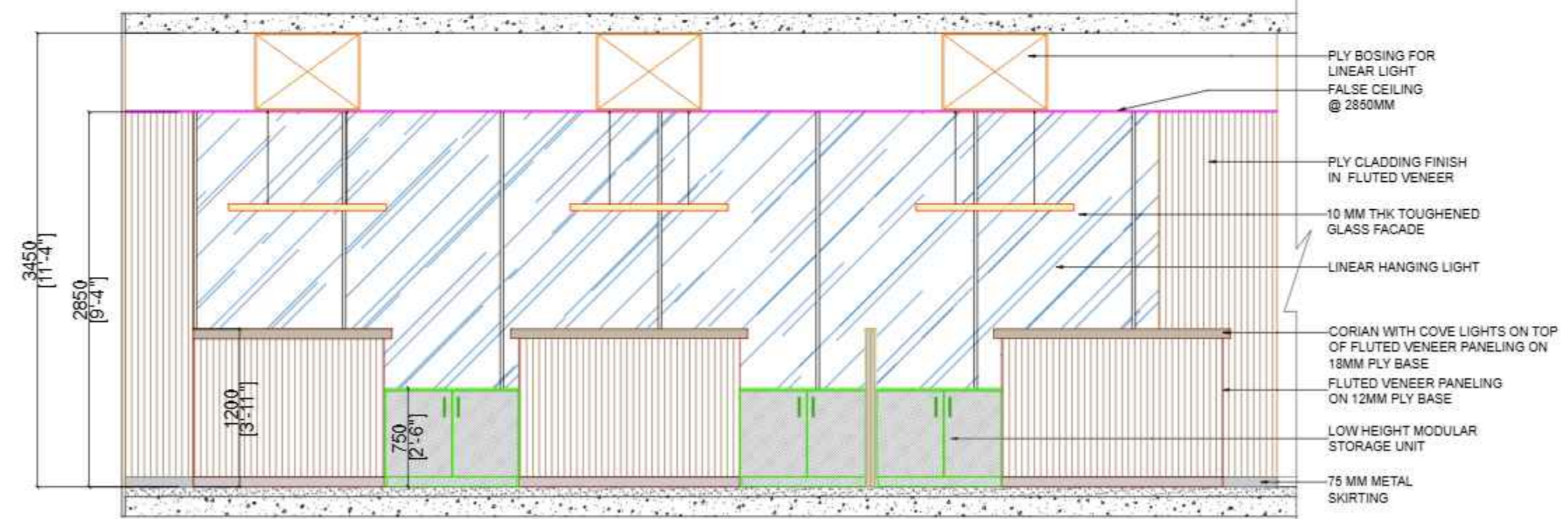

SECTION CC

NOTE:
THIS DRAWING IS THE SOLE PROPERTY OF 'M ETAPHORS'.
IT MUST NOT BE COPIED OR REPRODUCED IN ANYWAY OR
MADE ACCESSIBLE TO THIRD PARTY WITHOUT THE
WRITTEN APPROVAL OF THE OWNER.

LEGEND

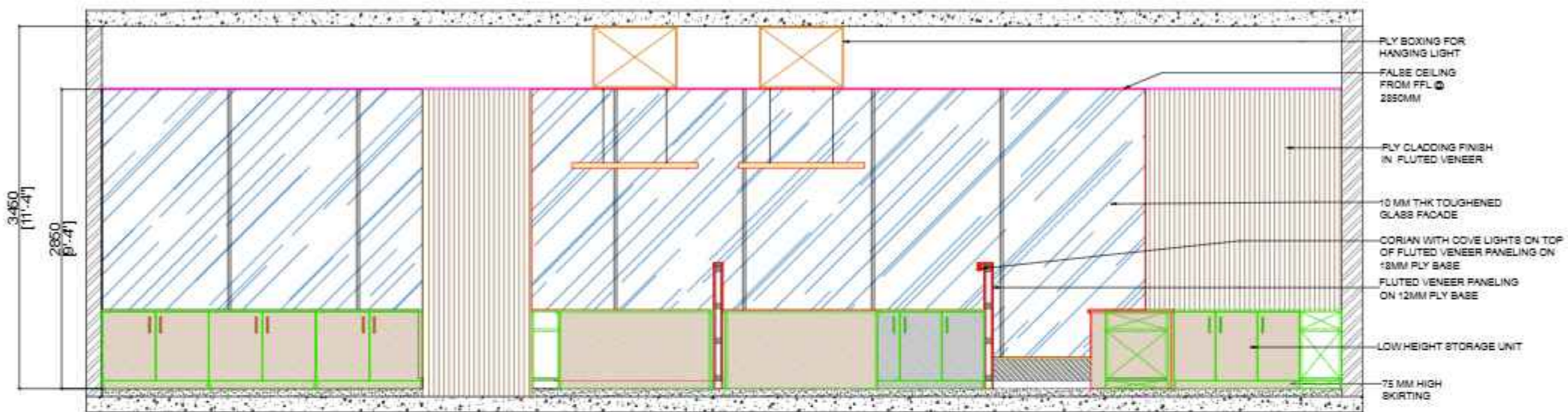

SECTION EE

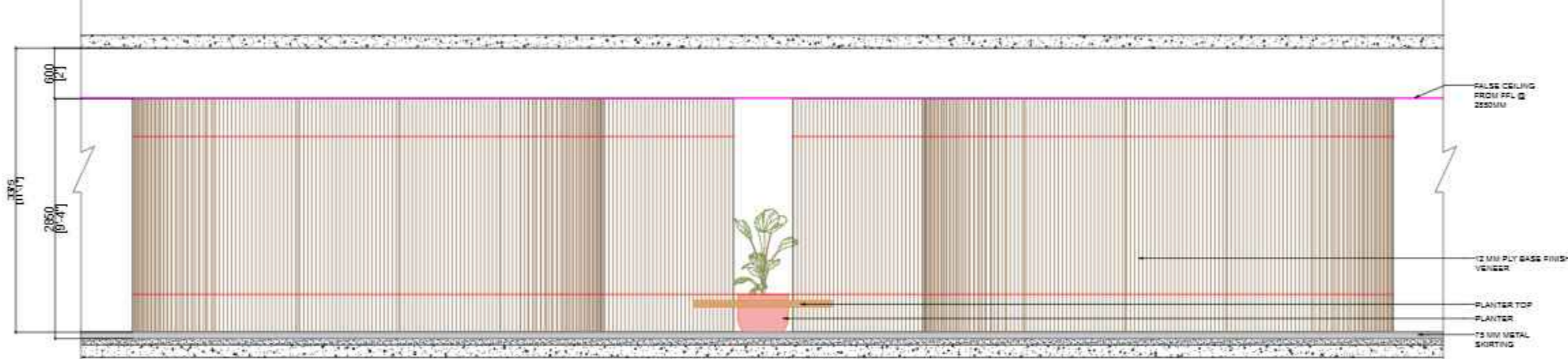

BACK SIDE ELEVATION H

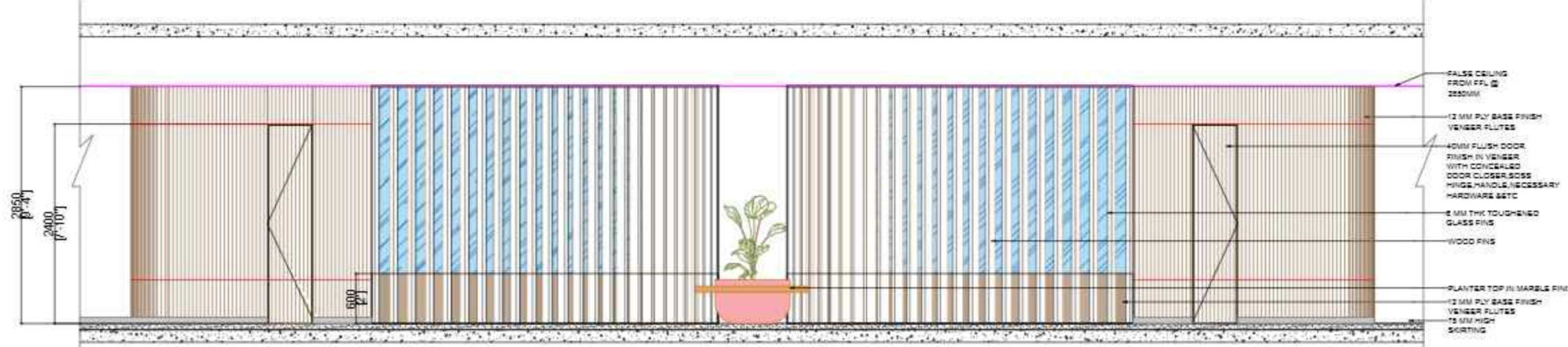

FRONT SIDE ELEVATION G

NOTE:
ALL DIMENSIONS ARE IN MM.
DO NOT SCALE THE DRAWING. ONLY WRITTEN DIMENSIONS TO BE
CONSIDERED.
ANY DISCREPANCY IN THE DRAWING SHALL BE BROUGHT TO NOTICE TO
ARCHITECT PRIOR TO EXECUTION.
THIS DRAWING IS PROPERTY OF ARCHITECT AND SHALL NOT BE
REPRODUCED OR USED WITHOUT EXPLICIT PERMISSION OF ARCHITECT
FOR STRUCTURAL DETAIL, REFER R.C.C. CONSULTANT'S DRAWING.

PROJECT NAME:
SBI-LHO, PUNE

DRAWING TITLE:
SBI_LHO_PUNE_12TH.FLOOR_PASSAGE
SECTIONS

DATE: 22.10.2024

REV	DATE	DESCRIPTION
1	27-12-2024	AS PER SITE MEASUREMENTS

	CONSULTANTS
	M.E.P. - Landscape -
SCALE N.T.S.	R.C.C. -

ARCHITECT'S STAMP & SIGNATURE:

DRAWN BY: SHIKHA CHK BY: PM

ARCHITECT:
metaphors
 beyond art and architecture
 ARCHITECTS & DESIGNERS

NOTE:
THIS DRAWING IS THE SOLE PROPERTY OF 'METAPHORS'.
IT MUST NOT BE COPIED OR REPRODUCED IN ANYWAY OR
MADE ACCESSIBLE TO THIRD PARTY WITHOUT THE
WRITTEN APPROVAL OF THE OWNER.

LEGEND

NOTE:
ALL DIMENSIONS ARE IN MM.
DO NOT SCALE THE DRAWING. ONLY WRITTEN DIMENSIONS TO BE
CONSIDERED.
ANY DISCREPANCY IN THE DRAWING SHALL BE BROUGHT TO NOTICE TO
ARCHITECT PRIOR TO EXECUTION.
THIS DRAWING IS PROPERTY OF ARCHITECT AND SHALL NOT BE
REPRODUCED OR USED WITHOUT EXPLICIT PERMISSION OF ARCHITECT
FOR STRUCTURAL DETAIL, REFER R.C.C. CONSULTANT'S DRAWING.

PROJECT NAME:
SBI-LHO, PUNE

DRAWING TITLE:
SBI_LHO_PUNE_12TH.FLOOR_PASSAGE
SECTIONS

DATE: 22.10.2024

REV	DATE	DESCRIPTION
1	27-12-2024	AS PER SITE MEASUREMENTS

CONSULTANTS	
M.E.P. -	
Landscape -	
SCALE	R.O.C. -
N.T.S.	

ARCHITECT'S STAMP & SIGNATURE

DRAWN BY:	SHIKHA	CHK BY:	PM
-----------	--------	---------	----

ARCHITECT:
metaphors
metaphors architects & designers

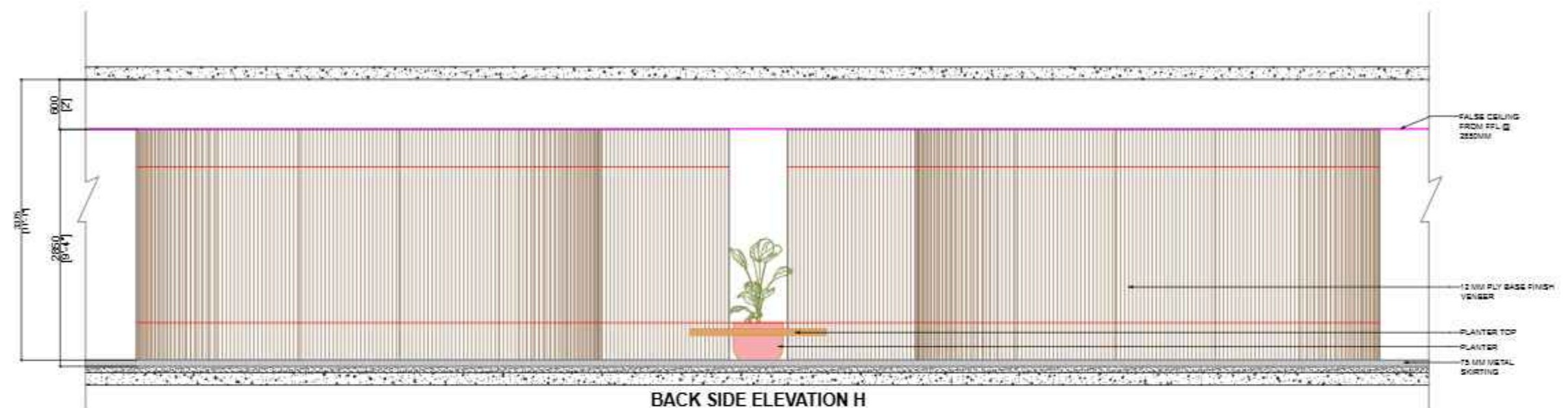

BACK SIDE ELEVATION H

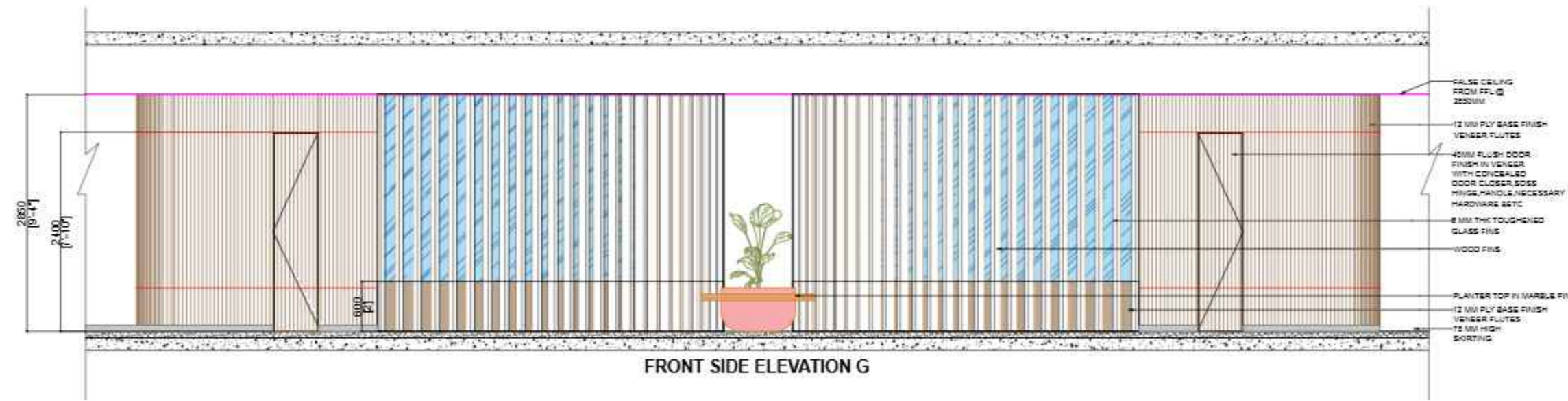

FRONT SIDE ELEVATION G

vertical partition in
ply+ veneer as per
selection

vertical partition in
ply+ mdf+ duco as
per selection

ply shutter with
veneer flutes

75mm metal
skirting

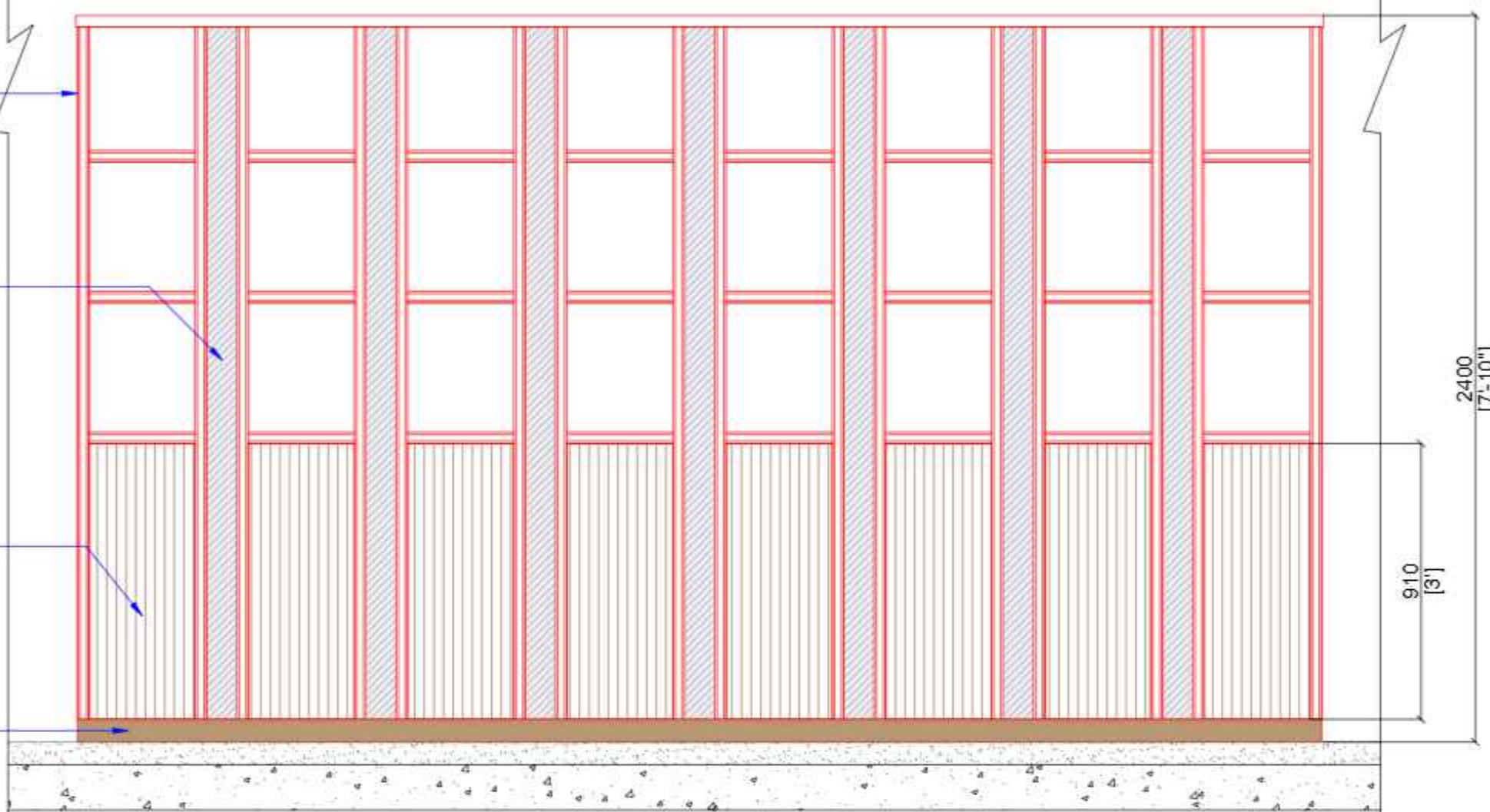

vertical partition in
ply+ veneer as per
selection

vertical partition in
ply+ veneer as per
selection

ply back +veneer
flutes

vertical partition in
ply+ mdf+ duco as
per selection

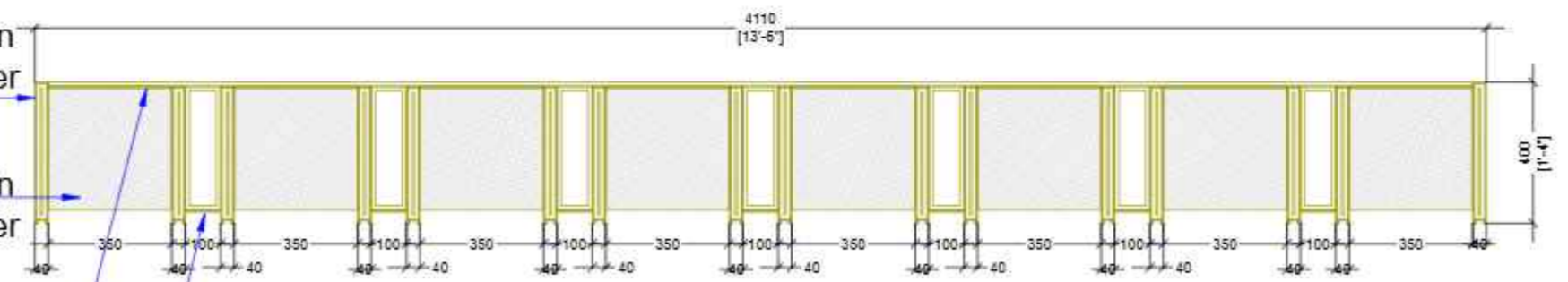

DWG NO.	SBI_LHO_PUNE_12TH.FL_ PG.SECTION_19	
NOTES:	THIS DRAWING IS THE SOLE PROPERTY OF 'METAPHORS'. IT MUST NOT BE COPIED OR REPRODUCED IN ANYWAY OR MADE ACCESSIBLE TO THIRD PARTY WITHOUT THE WRITTEN APPROVAL OF THE OWNER.	
LEGEND		
NOTE: ALL DIMENSIONS ARE IN MM. DO NOT SCALE THE DRAWING. ONLY WRITTEN DIMENSIONS TO BE CONSIDERED. ANY DISCREPANCY IN THE DRAWING SHALL BE BROUGHT TO NOTICE TO ARCHITECT PRIOR TO EXECUTION. THIS DRAWING IS PROPERTY OF ARCHITECT AND SHALL NOT BE REPRODUCED OR USED WITHOUT EXPLICIT PERMISSION OF ARCHITECT FOR STRUCTURAL DETAIL. REFER R.O.C. CONSULTANT'S DRAWING.		
PROJECT NAME:		
SBI-LHO, PUNE		
DRAWING TITLE:		
SBI_LHO_PUNE_12TH.FLOOR_TROPHY UNIT_PLAN & SECTION		
DATE: 22.10.2024		
REV	DATE	DESCRIPTION
1	27-12-2024	AS PER SITE MEASUREMENTS
CONSULTANTS		
M.E.P. -		
Landscape -		
SCALE		
N.T.S.		
R.O.C. -		
ARCHITECT'S STAMP & SIGNATURE		
DRAWN BY:	SHIKHA	CHK BY: PM
ARCHITECT:		
 metaphors Architects & Designers		
<small>© 2023, Plot (LHO) Sector, 47 (Bamboo) Road, Colaba (LHO) Pune (11) 6, India. Phone: +91-20-28878113 Fax: +91-20-28878114 Email: info@metaphorsdesign.com Website: www.metaphorsdesign.com</small>		

12mm ply

fluted veneer on
ply back

vertical partition in ply+
veneer as per selection

vertical partition in ply+
mdf+ duco as per selection

shelves in veneer finish

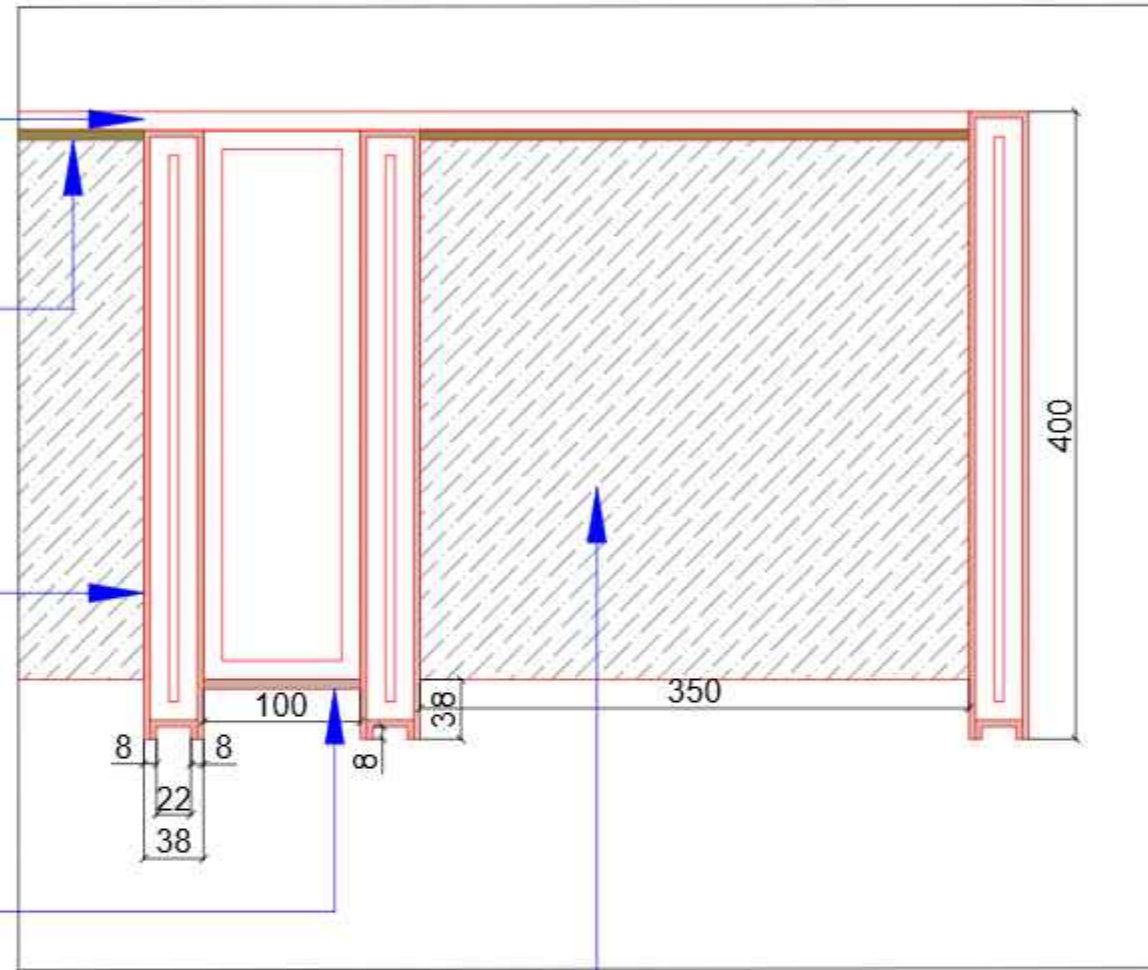

DWG NO.	SBI_LHO_PUNE_12TH.FL_PG.DETAILED_20		
NOTES: THIS DRAWING IS THE SOLE PROPERTY OF 'METAPHORS'. IT MUST NOT BE COPIED OR REPRODUCED IN ANYWAY OR MADE ACCESSIBLE TO THIRD PARTY WITHOUT THE WRITTEN APPROVAL OF THE OWNER.			
LEGEND			
<small>NOTE: ALL DIMENSIONS ARE IN MM. DO NOT SCALE THE DRAWING. ONLY WRITTEN DIMENSIONS TO BE CONSIDERED. ANY DISCREPANCY IN THE DRAWING SHALL BE BROUGHT TO NOTICE TO ARCHITECT PRIOR TO EXECUTION. THIS DRAWING IS PROPERTY OF ARCHITECT AND SHALL NOT BE REPRODUCED OR USED WITHOUT EXPLICIT PERMISSION OF ARCHITECT FOR STRUCTURAL DETAIL. REFER R.C.C. CONSULTANT'S DRAWING.</small>			
PROJECT NAME:			
SBI-LHO, PUNE			
DRAWING TITLE:			
SBI_LHO_PUNE_12TH.FL_TROPHY UNIT_DETAILS			
DATE: 22.10.2024			
REV	DATE	DESCRIPTION	
1	27-12-2024	AS PER SITE MEASUREMENTS	
CONSULTANTS			
M.E.P. -			
Landscape -			
SCALE	R.O.C. -		
N.T.S.			
ARCHITECT'S STAMP & SIGNATURE:			
DRAWN BY:	SHIKHA	CHK BY:	PM
ARCHITECT:			
<small>© 2022, Plot: Guna, Sector, 47, Baner, Pune, Maharashtra, India. Phone: +91-20-28875113 Fax: +91-20-28875114 Email: info@metaphorsdesign.com Website: www.metaphorsdesign.com</small>			